



SIP Industries

Quality Manufacturers Since 1960



Fabricator Products

www.sipindustries.com

Toll Free 877-921-6111



★★★
SIP INDUSTRIES
SERAMPORE
SINCE 1960

HIGH HUB DI 125 LB. THREADED FLANGES (for DI Pipe)

General Specifications

- Material** : Ductile Iron per ASTM A536
- Dimensions** : Per ANSI/AWWA C115/A21.15
- Pressure** : 250 PSI
- Flange Threads** : Taper pipe thread per ASME B1.20.1 adapted to ductile iron pipe O.D.
- Drilling** : In accordance with ANSI/AWWA C110/21.10, ASME B16.1 Class 125 and ASME B16.42 Class 150

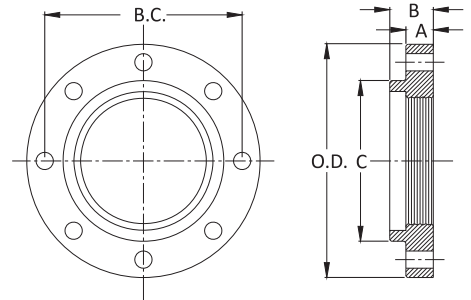

Technical Specifications

NOM. SIZE	PIPE OD	FLANGE THK. [A]	TOTAL THK. [B]	THREAD LENGTH	FLANGE OD [O.D.]	HUB DIA [C]	BOLT CIRCLE [B.C.]	BOLT HOLE DIA	BOLT SIZE DIA & LENGTH	BOLT HOLES #	WT. (LBS.)
2	2.50	0.62	1.25	1.00	6.00	3.06	4.75	3/4	5/8 X 2 1/4	4	4
3	3.96	0.75	1.69	1.25	7.50	4.25	6.00	3/4	5/8 X 2 1/2	4	7
4	4.80	0.94	1.81	1.37	9.00	5.32	7.50	3/4	5/8 X 3	8	12
6	6.90	1.00	2.00	1.53	11.00	7.56	9.50	7/8	3/4 X 3 1/2	8	17
8	9.05	1.12	2.25	1.75	13.50	9.69	11.75	7/8	3/4 X 3 1/2	8	26
10	11.10	1.19	2.44	1.88	16.00	12.00	14.25	1	7/8 X 4	12	37
12	13.20	1.25	2.56	2.12	19.00	14.06	17.00	1	7/8 X 4	12	55
14	15.30	1.38	2.62	2.12	21.00	16.25	18.75	1 1/8	1 X 4 1/2	12	70
16	17.40	1.44	2.75	2.12	23.50	18.44	21.25	1 1/8	1 X 4 1/2	16	80
18	19.50	1.56	3.00	2.25	25.00	20.53	22.75	1 1/4	1 1/8 X 5	16	85
20	21.60	1.69	3.25	2.44	27.50	22.63	25.00	1 1/4	1 1/8 X 5	20	106
24	25.80	1.88	3.50	2.75	32.00	26.82	29.50	1 3/8	1 1/4 X 5 1/2	20	147
30	32.00	2.12	3.75	3.37	38.75	32.75	36.00	1 3/8	1 1/4 X 6 1/2	28	224
36	38.30	3.38	5.00	4.00	46.00	39.12	42.75	1 5/8	1 1/2 X 7	32	337
42	44.50	2.62	5.12	4.50	53.00	46.00	49.50	1 5/8	1 1/2 X 7 1/2	36	495
48	50.80	2.75	5.50	4.75	59.50	52.25	56.00	1 5/8	1 1/2 X 8	44	622
54	57.56	3.00	6.45	5.12	66.25	58.75	62.75	2	1 3/4 X 8 1/2	44	711
60	61.61	3.12	6.75	5.00	73.00	63.00	69.25	2	1 3/4 X 9	52	1084
64	65.67	3.38	7.06	5.25	80.00	67.18	76.00	2	1 3/4 X 9	52	1575

REDUCING DI 125 LB. THREADED FLANGES (for DI Pipe)

General Specifications

- Material** : Ductile Iron per ASTM A536
- Dimensions** : Per ANSI/AWWA C115/A21.15
- Pressure** : 250 PSI
- Flange Threads** : Taper pipe thread per ASME B1.20.1 adapted to ductile iron pipe O.D.
- Drilling** : In accordance with ANSI/AWWA C110/21.10, ASME B16.1 Class 125 and ASME B16.42 Class 150

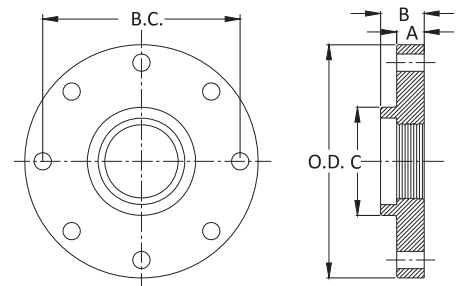

Technical Specifications

NOM. SIZE	PIPE OD	FLANGE THK. [A]	TOTAL THK. [B]	THREAD LENGTH	FLANGE OD [O.D.]	HUB DIA [C]	BOLT CIRCLE [B.C.]	BOLT HOLE DIA	BOLT SIZE DIA & LENGTH	BOLT HOLES #	WT. (LBS.)
4 X 3	3.96	0.94	1.37	0.94	9.00	4.50	7.50	3/4	5/8 X 3	8	16
6 X 4	4.80	1.00	1.56	1.00	11.00	5.32	9.50	7/8	3/4 X 3 1/2	8	25
8 X 4	4.80	1.12	1.75	1.00	13.50	5.32	11.75	7/8	3/4 X 3 1/2	8	40
8 X 6	6.90	1.12	1.75	1.16	13.50	7.56	11.75	7/8	3/4 X 3 1/2	8	35
10 X 8	9.05	1.19	2.00	1.38	16.00	9.69	14.25	1	7/8 X 4	12	50
12 X 8	9.05	1.25	2.19	1.38	19.00	9.69	17.00	1	7/8 X 4	12	85
12 X 10	11.10	1.25	2.19	1.38	19.00	12.00	17.00	1	7/8 X 4	12	65

All dimensions are in inches unless noted otherwise.

All weights are approximate in pounds unless noted otherwise.

TAPPED FOR STUDS DI 125 LB. THREADED FLANGES (for DI Pipe)

General Specifications

- Material** : Ductile Iron per ASTM A536
- Dimensions** : Per ANSI/AWWA C115/A21.15
- Pressure** : 250 PSI
- Flange Threads** : Taper pipe thread per ASME B1.20.1 adapted to ductile iron pipe O.D.
- Bolt Hole Threads** : UNC-2B Per ASME B1.1
- Drilling** : In accordance with ANSI/AWWA C110/21.10, ASME B16.1 Class 125 and ASME B16.42 Class 150

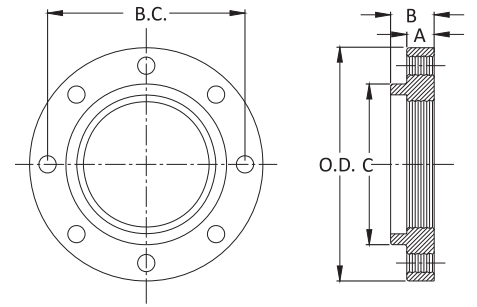

Technical Specifications

NOM. SIZE	PIPE OD	FLANGE THK. [A]	TOTAL THK. [B]	THREAD LENGTH	FLANGE OD [O.D.]	HUB DIA [C]	BOLT CIRCLE [B.C.]	BOLT HOLES THREADS (UNC-2A)	BOLT HOLES #	WT. (LBS.)
2	2.50	0.62	1.25	1.00	6.00	3.06	4.75	5/8 - 11	4	4
3	3.96	0.75	1.69	1.25	7.50	4.25	6.00	5/8 - 11	4	7
4	4.80	0.94	1.81	1.37	9.00	5.32	7.50	5/8 - 11	8	12
6	6.90	1.00	2.00	1.53	11.00	7.56	9.50	3/4 - 10	8	17
8	9.05	1.12	2.25	1.75	13.50	9.69	11.75	3/4 - 10	8	26
10	11.10	1.19	2.44	1.88	16.00	12.00	14.25	7/8 - 9	12	37
12	13.20	1.25	2.56	2.12	19.00	14.06	17.00	7/8 - 9	12	55
14	15.30	1.38	2.62	2.12	21.00	16.25	18.75	1 - 8	12	70
16	17.40	1.44	2.75	2.12	23.50	18.44	21.25	1 - 8	16	80
18	19.50	1.56	3.00	2.25	25.00	20.53	22.75	1 1/8 - 7	16	85
20	21.60	1.69	3.25	2.44	27.50	22.63	25.00	1 1/8 - 7	20	106
24	25.80	1.88	3.50	2.75	32.00	26.82	29.50	1 1/4 - 7	20	147
30	32.00	2.12	3.75	3.37	38.75	32.75	36.00	1 1/4 - 7	28	224
36	38.30	3.38	5.00	4.00	46.00	39.12	42.75	1 1/2 - 6	32	337
42	44.50	2.62	5.12	4.50	53.00	46.00	49.50	1 1/2 - 6	36	495
48	50.80	2.75	5.50	4.75	59.50	52.25	56.00	1 1/2 - 6	44	622
54	57.56	3.00	6.45	5.12	66.25	58.75	62.75	1 3/4 - 5	44	711
60	61.61	3.12	6.75	5.00	73.00	63.00	69.25	1 3/4 - 5	52	1084
64	65.67	3.38	7.06	5.25	80.00	67.18	76.00	1 3/4 - 5	52	1575

DUCTILE IRON 250 LB. THREADED FLANGES (for DI Pipe)

General Specifications

- Material** : Ductile Iron per ASTM A536
- Dimensions** : Per ANSI/B16.1 Class 250 and ASME B16.42 Class 300
- Pressure** : 640 PSI
- Flange Threads** : Taper pipe thread per ASME B1.20.1 adapted to ductile iron pipe O.D.
- Drilling** : In accordance with ASME B16.1 Class 250 and ASME B16.42 Class 300

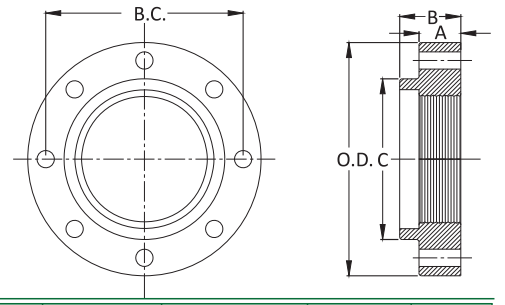

Technical Specifications

NOM. SIZE	PIPE OD	FLANGE THK. [A]	TOTAL THK. [B]	THREAD LENGTH	FLANGE OD [O.D.]	HUB DIA [C]	BOLT CIRCLE [B.C.]	BOLT HOLE DIA	BOLT SIZE DIA & LENGTH	BOLT HOLES #	WT. (LBS.)
3	3.96	1.12	1.56	1.19	8.25	4.62	6.62	7/8	3/4 X 3 1/2	8	10
4	4.80	1.25	1.75	1.31	10.00	5.75	7.88	7/8	3/4 X 4	8	19
6	6.90	1.44	1.94	1.56	12.50	8.12	10.62	7/8	3/4 X 4	12	31
8	9.05	1.62	2.19	1.75	15.00	10.25	13.00	1	7/8 X 4 1/2	12	47
10	11.10	1.88	2.38	1.94	17.50	12.62	15.25	1 1/8	1 X 5 1/2	16	70
12	13.20	2.00	2.56	2.19	20.50	14.75	17.75	1 1/4	1 1/8 X 5 1/2	16	114
14	15.30	2.12	2.69	2.25	23.00	16.25	20.25	1 1/4	1 1/8 X 6	20	122
16	17.40	2.25	2.88	2.50	25.50	18.38	22.50	1 3/8	1 1/4 X 6 1/2	20	159
18	19.50	2.38	3.00	2.56	28.00	20.53	24.75	1 3/8	1 1/4 X 6 1/2	24	205
20	21.60	2.50	3.31	2.87	30.50	22.63	27.00	1 3/8	1 1/4 X 7	24	220
24	25.80	2.75	3.75	3.25	36.00	26.82	32.00	1 5/8	1 1/2 X 7 1/2	24	342
30	32.00	3.00	4.75	4.33	43.00	35.00	39.25	2	1 3/4 X 8 1/2	28	502
36	38.30	3.38	5.37	4.63	50.00	41.25	46.00	2 1/4	2 X 9 1/2	32	690
42	44.50	3.69	6.00	5.38	57.00	48.50	52.75	2 1/4	2 X 10	36	986
48	50.80	4.00	6.63	6.25	65.00	56.55	60.75	2 1/4	2 X 11	40	1499

All dimensions are in inches unless noted otherwise.

All weights are approximate in pounds unless noted otherwise.

DUCTILE IRON MJ THREADED BELL (for DI Pipe)

General Specifications

Material	: Ductile Iron per ASTM A536
Dimensions	: MJ BELL per ANSI/AWWA C111/A21.11
Pressure	: 350 PSI 3" - 24" and 250 PSI 30"-48"
Flange Threads	: Taper pipe thread per ASME B1.20.1 adapted to ductile iron pipe O.D.
Drilling	: In accordance with ANSI/AWWA C111/21.11
Bolt Hole Threads	: UNC-2B per ASME B1.1

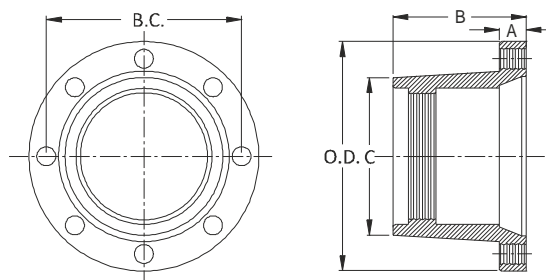

Technical Specifications

NOM. SIZE	PIPE OD	FLANGE THK. [A]	TOTAL THK. [B]	THREAD LENGTH	FLANGE OD [O.D.]	HUB DIA [C]	BOLT CIRCLE [B.C.]	BOLT HOLES THREADS (UNC-2A)	BOLT HOLES #	WT. (LBS.)
3	3.96	0.94	4.12	0.94	7.69	4.50	6.19	5/8 - 11	4	11
4	4.80	1.00	4.25	1.00	9.12	5.32	7.50	3/4 - 10	4	15
6	6.90	1.06	4.43	1.16	11.12	7.56	9.50	3/4 - 10	6	22
8	9.05	1.12	4.75	1.38	13.37	9.73	11.75	3/4 - 10	6	35
10	11.10	1.19	4.87	1.50	15.69	12.06	14.00	3/4 - 10	8	46
12	13.20	1.25	5.12	1.75	17.94	14.16	16.25	3/4 - 10	8	55
14	15.30	1.31	6.50	1.87	20.31	16.25	18.75	3/4 - 10	10	94
16	17.40	1.38	6.75	2.06	22.58	18.44	21.00	3/4 - 10	12	118
18	19.50	1.44	7.00	2.25	24.83	20.53	23.25	3/4 - 10	12	125
20	21.60	1.50	7.25	2.44	27.08	22.63	25.50	3/4 - 10	14	150
24	25.80	1.62	7.50	2.75	31.58	26.82	30.00	3/4 - 10	16	235
30	32.00	1.81	9.13	3.37	39.12	32.75	36.88	1 - 8	20	375
36	38.30	2.00	9.75	4.00	46.00	39.12	43.75	1 - 8	24	500
42	44.50	2.00	10.50	4.00	53.12	46.00	50.62	1 1/4 - 7	28	735
48	50.80	2.00	11.00	4.12	60.00	52.25	57.50	1 1/4 - 7	32	940
54	57.56	2.00	11.50	4.25	65.70	59.18	63.20	1 1/4 - 7	36	978
60	61.61	2.00	11.50	5.00	70.22	63.00	67.72	1 1/4 - 7	36	1109

CAST IRON FILLER FLANGES

General Specifications

Material	: Gray Cast Iron as per ASTM A48
Drilling	: In accordance with ANSI/AWWA C110/21.10, ASME B16.1 Class 125 and ASME B16.42 Class 150

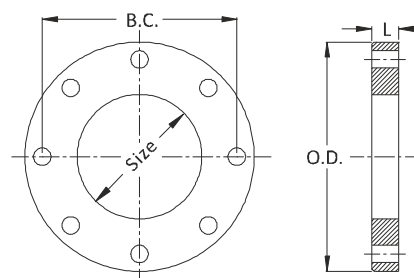

Technical Specifications

Nom. Size	Flange OD [O.D.]	Bolt Circle [B.C.]	Bolt Hole Dia	Bolt Holes #	Weight for Length [L] (LBS.)								
					1/2	3/4	1	1 1/2	2	3	4	5	6
3	7.50	6.00	3/4	4	5	7	9	14	18	27	36	45	54
4	9.00	7.50	3/4	8	6	9	12	19	25	37	49	62	74
6	11.00	9.50	7/8	8	8	12	16	24	32	48	64	81	97
8	13.50	11.75	7/8	8	11	17	23	34	46	69	92	114	137
10	16.00	14.25	1	12	15	22	29	44	59	88	118	147	176
12	19.00	17.00	1	12	21	31	42	63	84	126	167	209	251
14	21.00	18.75	1 1/8	12	23	35	47	70	94	141	188	235	282
16	23.50	21.25	1 1/8	16	28	42	56	85	113	169	225	282	338
18	25.00	22.75	1 1/4	16	28	42	56	85	113	169	225	282	338
20	27.50	25.00	1 1/4	20	33	50	66	100	133	199	265	332	398
24	32.00	29.50	1 3/8	20	42	63	84	126	167	251	335	419	502
30	38.75	36.00	1 3/8	28	56	84	112	168	224	336	448	560	672
36	46.00	42.75	1 3/8	32	75	113	150	225	300	450	601	751	901

All dimensions are in inches unless noted otherwise.

All weights are approximate in pounds unless noted otherwise.

DUCTILE IRON ANCHOR FLANGES / WALL COLLARS

General Specifications

Material : Ductile Iron per ASTM A536

Technical Specifications

NOM. SIZE	THICKNESS [T]	FLANGE OD [O.D.]	ID FLANGE [A]	WT. (LBS.)
3	0.50	6.50	4.03	3
4	0.50	7.40	4.87	4
6	0.50	9.50	6.97	5
8	0.50	12.00	9.13	7
10	0.50	14.10	11.17	8
12	0.50	16.25	13.27	10
14	0.50	18.40	15.38	12
16	0.50	21.00	17.48	15
18	0.50	23.10	19.59	17
20	0.50	25.70	21.69	21
24	0.50	30.00	25.90	25
30	0.63	37.00	32.10	47
36	0.63	43.40	38.40	53
42	1.00	50.00	44.62	104
48	1.00	56.50	50.94	122
54	1.25	62.50	57.73	147
60	1.25	69.00	61.78	241
64	1.25	75.75	65.84	358

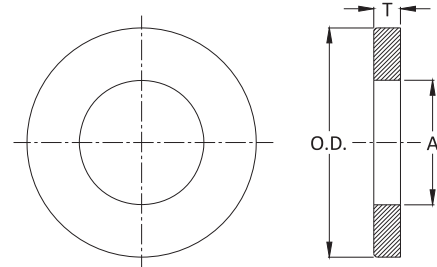

PLAIN END MJ BELL ADAPTERS

General Specifications

Material : Ductile Iron per ASTM A536

Technical Specifications

NOM. SIZE	L	D	WT. (LBS.)
3	24	7.69	39
4	24	9.12	50
6	24	11.12	76
8	24	13.37	107
10	24	15.69	146
12	24	17.94	193
14	24	20.31	184
16	24	22.56	231
18	24	24.83	269
20	24	27.08	360
24	24	31.58	436
30	24	39.12	737
36	24	46.00	1084
42	24	53.12	1228
48	24	60.00	1546

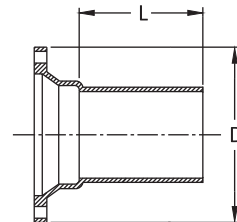

SIP INDUSTRIES TREATMENT PLANT DIVISION SERVICES

Dedicated Treatment Plant Division Services :

- Project Tracking and Quotes.
- Project Management.
- Specification Assistance.



Value Added Services :

- In house Engineering services for Custom Product Development.
- In house drilling / tapping capability.
- In house exterior coating capability for most Tnemec products.
- Customer specific Tagging options.

Available Exterior Coatings :

- Bare.
- Bituminous Tar Coat.
- Most Tnemec Primers.
- Fusion Bonded Epoxy.



Available Interior Linings :

- Bare.
- Cement Lining Single & Double.
- Fusion Bonded Epoxy.
- P401 Ceramic Epoxy.



TREATMENT PLANT DIVISION CONTACTS

Treatment Plant Sales

Mike Mansfield
Mobile# 817-757-2704
mmansfield@sipindustries.com

Treatment Plant Quotes / Project Manager

Stacie Roberts
Mobile# 817-659-3700
sroberts@sipindustries.com



SIP Industries

Quality Manufacturers Since 1960

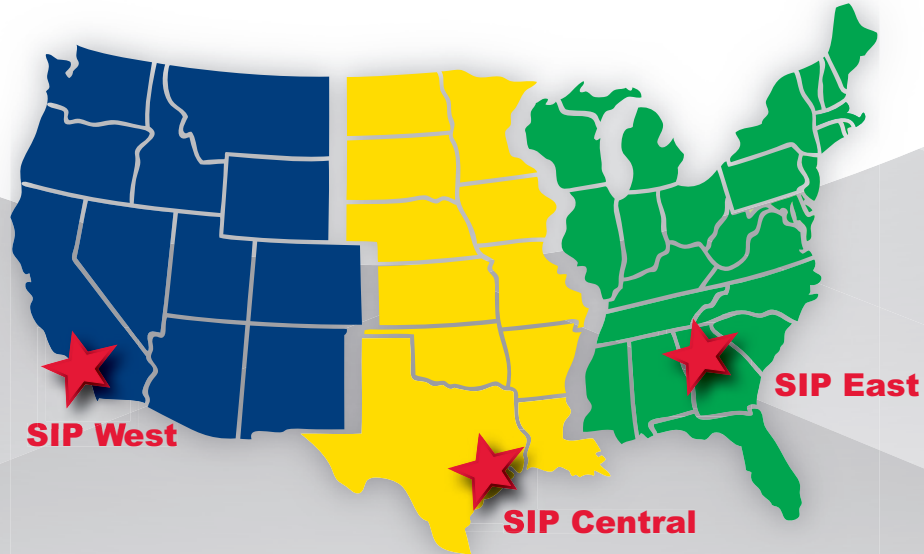

PRODUCT LINE

AWWA DI Fittings & Accessories

- C153 Compact MJ Fittings and Acc. 2" - 64"
- C110 Full Body MJ Fittings 2" - 64"
- C153 Trim Tyton® Push-On Fittings 4" - 24"
- C110 Flange Fittings 2" - 64"
- MJ x MJ Adapter for Connecting MJ Bells 3" - 24"
- Stainless Steel & Blue T-Bolts
- Made in India, China & Mexico
- Bare, Cement, Zinc, FBE & Other Linings

Joint Restraint System

- EZD Joint Restraint for DI Pipe 3" - 48"
- EZDTP Joint Restraint Tandem for DI Pipe 3" - 48"
- EZDPTP Joint Restraint for Push-On Joints DI Pipe 3" - 48"
- Ductile Iron Retainer Glands 3" - 30"
- FAR / FAH Flange Adapter for DI Pipe 3" - 48"
- EZFA Restrained Flange Adapter for DI and PVC Pipe 3" - 36"
- EZPVC Joint Restraint for PVC Pipe 3" - 36"
- ULTRA Joint Restraint for PVC Pipe 4" - 12"
- EZPVCPTP Joint Restraint for Push-On Joints PVC Pipe 14" - 36"
- PTPVC Pipe to Pipe Restraint 4" - 48"
- PTPDF Pipe to MJ Fittings Restraint 4" - 48"
- PTPFC Pipe to PVC Fittings Restraint 4" - 12"
- Made in China & USA
- EZ Shield or Shop Coating

Municipal Construction Castings

- Manhole Rings and Cover
- Frames and Grates
- Valve Boxes and Service Boxes
- Water Meter Covers and Boxes
- Cleanout and Monument Boxes
- Detectable Warning Plates
- Extension Rings
- Trench Grates and Tree Grates
- Made in India & USA

Fabrication Products for DI Pipe

- High Hub Flanges Class 150 and 250. 3" - 64"
- Threaded Bell Flanges 3" - 48"
- Anchor Flanges 3" - 60"
- Filler Flanges 4" - 30"

Other Products and Services

- All Thread Rod
- Pipe Lube and Hydraulic Cement
- Socket Clamps and Lugs
- Flange Packs
- OEM Castings



SIP CORPORATE 8876 Gulf Freeway, Suite 500, Houston, TX 77017

SIP CENTRAL 2900 Patio Drive, Houston, TX 77017

SIP EAST 600 Rayloc Drive, Atlanta, GA 30336

SIP WEST 8333 Almeria Avenue, Fontana, CA 92335

Phone: 877-921-6111 or 713-923-6111 | Fax: 713-923-6114 | www.sipindustries.com | sales@sipindustries.com