



SIP Industries
Quality Manufacturers Since 1960

EZ GRIP®
PTP SERIES

BELL JOINT RESTRAINT FOR PVC PIPE

The EZ GRIP®

Pipe-To-Pipe Joint Restraint is a proven design, offering an efficient, reliable, and inexpensive method of restraining PVC Bell and Spigot (Push-On) Joints by utilizing a series of rigid machined gripping serrations that grab, hold, and secure the PVC Bell and Spigot ends.

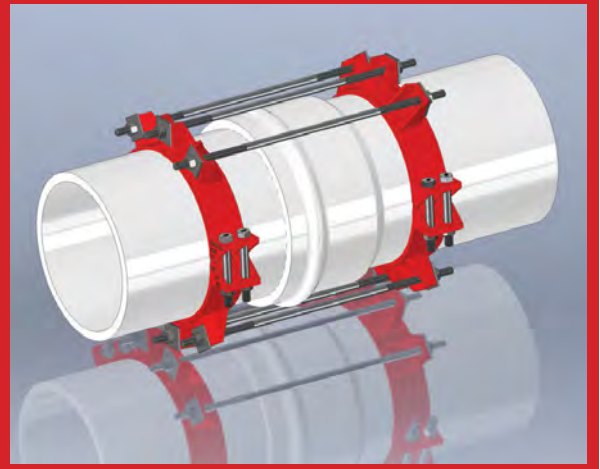

ADVANTAGES, BENEFITS, FEATURES

- The PTP Joint Restraint eliminates the need of timely thrust blocks.
- The PTP Joint Restraint performs optimally with AWWA C900 (PVC), C906 (HDPE), C909 (PVCO), or ASTM D2241 IPS PVC Pipe.
- Composed of high strength Ductile Iron in compliance with the ASTM A536 Standard, Grade 65-45-12
- T-Bolts, Rods, and Hex nut are manufactured from high-strength low-alloy (HSLA) steel as per ANSI/AWWA C111/A21.11
- Machined to exact tolerances with a minimum safety factor of 2:1.
- Easily maintains a water working pressure equal to that of the PVC pipe on which it is installed
- The PTP Joint Restraint is designed and manufactured to be disassembled, reinstalled, and reusable.
- The PTP Joint Restraint can be installed on new or existing water systems.
- The PTP Joint Restraint allows full joint deflection and maintains the seal while under pressure, and while subjected to ground movements.
- The internal serrations offer 360° circumferential contact with the pipe wall and increase the grip as the hydrostatic pressure increases whilst concurrently offering support of the pipe wall.
- With the split castings, the PTP Joint Restraint can conveniently be installed in or outside the trench.
- The PTP Joint Restraint for PVC Pipe is provided with a coating that is compatible with most field applied coatings. The standard color of the PTP Joint Restraint is red.
- Offered in sizes from 4" up to 48".
- Approved by Factory Mutual (FM) for sizes 4"-12" at 185psi for AWWA C900 Class 235 DR-18 pipe.



Available: Import

Toll Free 877-921-6111

www.sipindustries.com

V 0524-01

Installation Procedure: 4" - 12"

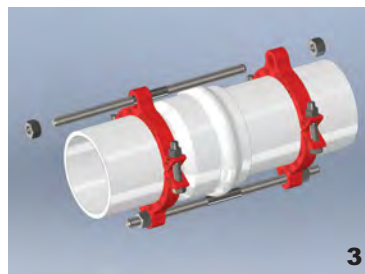
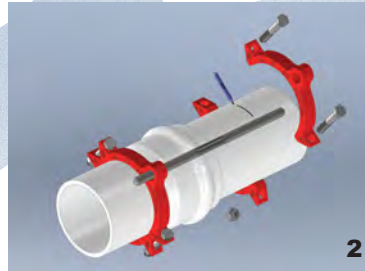
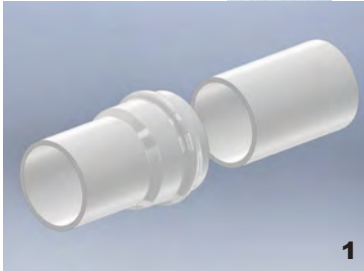

1 Assemble the plain-end of the pipe into the pipe bell utilizing the normal procedure as per pipe manufacturer.

2 Assemble one restrainer immediately behind the pipe bell and tighten the restrainer clamping bolts evenly to the recommended torque (see table below). Completely insert one of the provided restraint rods through one of the assembled restrainer gland holes so that approximately 1" of the rod remains on the backside of the gland (see pic. 2). Mark a line on the spigot side of the joint approximately 1" from the end of the rod (see pic. 2) as shown. Assemble the second restrainer evenly with the mark on the spigot end of the pipe. Align the restraint holes by using one of the provided restraining rods. Tighten restrainer clamping bolts to the recommended torque on the second restrainer after it is aligned with the first one.

3 Insert the provided restrainer rods through the restrainers. Snug tight the remaining nuts behind the restrainer ears against the flat surface in a way that spigot end is secured into the bell pipe.

NOTE:

Do not over-tighten the restrainer nuts. Hand tight the nuts plus about one turn with wrench.

Installation Procedure: 14" - 48"

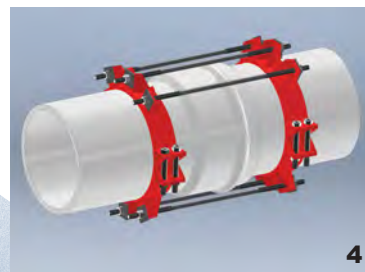
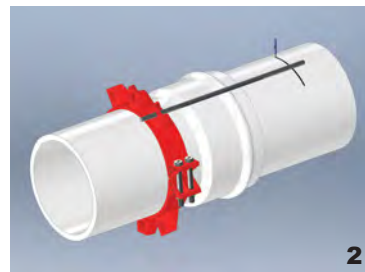
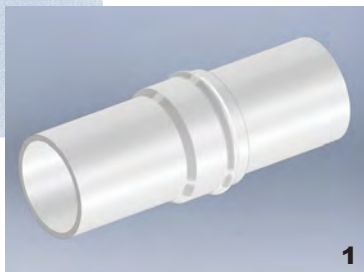

1 Assemble the plain-end of the pipe into the pipe bell utilizing the normal procedure as per pipe manufacturer.

2 Assemble one restrainer immediately behind the pipe bell and tight the restrainer clamping bolts evenly to the recommended torque (see table below). Completely insert one of the provided restraint rods through one of the assembled restrainer gland holes so that approximately 1" of the rod remains on the backside of the gland (see pic. 2). Mark a line on the spigot side of the joint approximately 1" from the end of the rod (see pic. 2) as shown.

3 Assemble the second restrainer evenly with the mark on the spigot end of the pipe. Align the restraint holes by using one of the provided restraining rods. Tighten restrainer clamping bolts to the recommended torque on the second restrainer after it is aligned with the first one.

4 Insert the provided restrainer rods through the restrainers. Place a washer behind each restrainer ear against the flat surface and snug tight all of the retainer nuts in a way that spigot end is secured into the bell pipe.

NOTE:

Do not over-tighten the restrainer nuts. Hand tight the nuts plus about one turn with wrench.

RECOMMENDED TORQUE (CLAMPING BOLTS)	
PIPE SIZE (IN)	RANGE OF TORQUE (FT/LBS)
4-12	90-110
14-16	150-200
18	175-225
20	200-250
24-36	225-275
42-48	300-350

Technical Data

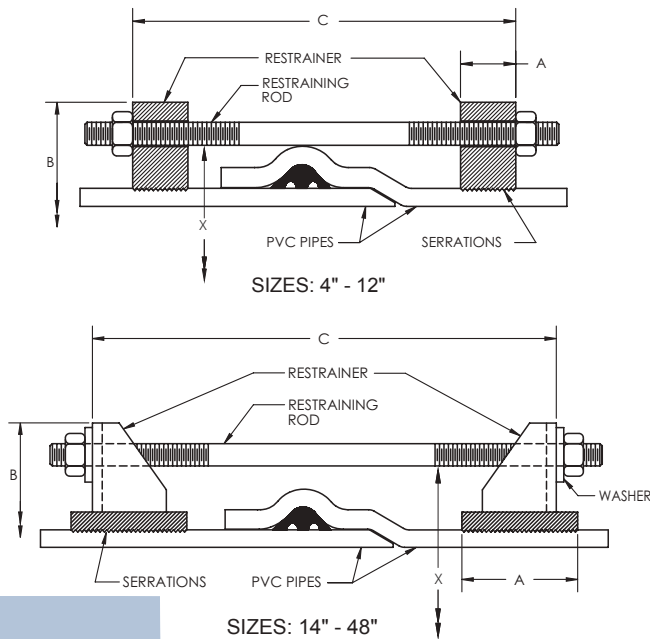

STANDARDIZED PRESSURE RATINGS									
Size	ANSI/AWWA C900 CI OD								
	DR14	DR17	DR18	DR21	DR25	DR27.5	DR32.5	DR41	DR51
4	200	-	150	-	100	-	-	-	-
6	200	-	150	-	100	-	-	-	-
8	200	-	150	-	100	-	-	-	-
10	200	-	150	-	100	-	-	-	-
12	200	-	150	-	100	-	-	-	-
14	305	250	235	200	165	-	-	-	-
16	-	250	235	200	165	-	-	-	-
18	-	250	235	200	165	-	-	-	-
20	-	-	235	200	165	-	-	-	-
24	-	-	235	200	165	-	-	-	-
30	-	-	235	200	165	150	125	100	80
36	-	-	235	200	165	150	125	100	80
42	-	-	-	200	165	150	125	100	80
48	-	-	-	-	165	150	125	100	80

RECOMMENDED TORQUE (CLAMPING BOLTS)	
PIPE SIZE (IN)	RANGE OF TORQUE (FT/LBS)
4-12	90-110
14-16	150-200
18	175-225
20	200-250
24-36	225-275
42-48	300-350

STANDARDIZED PRESSURE RATINGS					
Size	ANSI/AWWA C909 PVCO		ASTM D2241 IPS OD		
	PC235	PC165	SDR17	SDR21	SDR26
4	-	-	250	200	160
6	-	-	250	200	160
8	-	-	250	200	160
10	-	-	250	200	160
12	-	-	250	200	160
14	235	-	-	-	-
16	200	165	-	-	-
18	200	-	-	-	-
20	-	-	-	-	-
24	-	-	-	-	-
30	-	-	-	-	-
36	-	-	-	-	-
42	-	-	-	-	-
48	-	-	-	-	-

PTPVC PIPE RESTRAINTS SPECIFICATIONS

Size	C900 PVC Pipe PTPVC Series		IPS PVC Pipe PTPVS Series		A	B (Approx.)	C (Max.)	X (Min.)	Restraint Bolts/Rods		Clamping Bolts		Approx. Weight (Lbs)
	O.D.	Item Code	O.D.	Item Code					Qty	Size	Qty	Size	
4	4.80	PTPVC04	4.50	PTPS04	1.12	9.15	15.00	6.29	2	¾ X 17	4	¾ X 3 ½	16
6	6.90	PTPVC06	6.63	PTPS06	1.15	11.12	15.00	8.13	2	¾ X 17	4	¾ X 3 ½	20
8	9.05	PTPVC08	8.63	PTPS08	1.47	14.75	15.00	10.60	2	¾ X 17	4	¾ X 4	32
10	11.10	PTPVC10	10.75	PTPS10	1.38	16.82	22.00	12.66	4	¾ X 24	4	¾ X 5	52
12	13.20	PTPVC12	12.75	PTPS12	1.42	19.45	22.00	14.80	4	¾ X 24	4	¾ X 5	56
14	15.30	PTPVC14	N/A	N/A	4.00	22.56	27.00	18.10	6	¾ X 30	8	¾ X 7	150
16	17.40	PTPVC16	N/A	N/A	4.00	24.64	27.00	20.20	6	¾ X 30	8	¾ X 7	154
18	19.50	PTPVC18	N/A	N/A	5.00	26.64	27.00	22.30	8	¾ X 30	8	¾ X 7	222
20	21.60	PTPVC20	N/A	N/A	5.00	28.75	33.00	24.60	8	¾ X 36	8	1 ½ X 9	195
24	25.80	PTPVC24	N/A	N/A	5.00	33.90	33.00	28.80	12	¾ X 36	8	1 ½ X 9	237
30	32.00	PTPVC30N	N/A	N/A	5.50	40.75	38.00	35.56	10	1 X 40	8	1 ¼ X 8 ½	475
36	38.30	PTPVC36N	N/A	N/A	7.00	47.25	38.00	42.43	12	1 X 40	12	1 ½ X 6	722
42	44.50	PTPVC42	N/A	N/A	6.30	56.25	46.00	49.08	16	1 ¼ X 48	8	1 ½ X 9	1180
48	50.80	PTPVC48	N/A	N/A	6.90	63.64	46.00	56.35	16	1 ¼ X 48	12	1 ½ X 11	2443

All dimensions in inches, unless stated otherwise.

Please contact SIP for technical assistance of nonstandard applications, pressures and bell dimensions that exceed listed X dimensions

Please refer to our web page www.sipindustries.com for up to date product data and technical advisories



SIP Industries
Quality Manufacturers Since 1960

EZ GRIP®
PTP SERIES

BELL JOINT RESTRAINT FOR PVC PIPE

SAMPLE SPECIFICATIONS

The bell and spigot (push-on) joint restraining mechanism shall be designed and manufactured as two identical halves providing a joint restraint. The bell and spigot (push-on) joint restraint shall be compatible with AWWA C900, C906, C909 and ASTM D2241 PVC Pipe and shall contain a series of rigid integrally machined serrations that grip the outside wall of the PVC Pipe. The bell and spigot (push-on) joint restraint shall have the same pressure rating as the pipe with a 2:1 safety factor. The grip of the serrations shall increase as the hydrostatic pressure increases.

There shall be no additional tool required for installation other than the tools required to install standard sizes of hex nuts from 5/8"-1 1/4". The hex heads, bolts and rods shall be designed to tighten clockwise. The hex heads, bolts and rods shall be manufactured to allow for disassembly and re-installation of the restraint.

The gland halves shall be manufactured of high strength ductile iron in accordance with the ASTM A536 Standard, Grade 65-45-12.

Rods and hex nuts are manufactured from high-strength low-alloy (HSLA) steel as per ANSI/AWWA C111/A21.11.

The restraining gland shall comply with all applicable dimensions of ANSI/AWWA C111/A21.11 and shall be compatible with all bell and spigot (push-on) joint sockets of the standard.

The restraint device for PVC pipe-to pipe shall be approved by Factory Mutual for sizes 4"-12".

The restraint device for PVC Pipe shall be SIP Industries series PTPVC or equal.

Available: Import



PRODUCT LINE

AWWA DI Fittings & Accessories

- C153 Compact MJ Fittings and Acc. 2" - 64"
- C110 Full Body MJ Fittings 2" - 64"
- C153 Trim Tyton® Push-On Fittings 4" - 24"
- C110 Flange Fittings 2" - 64"
- MJ x MJ Adapter for Connecting MJ Bells 3" - 24"
- Stainless Steel & Blue T-Bolts
- Made in India, China & Mexico
- Bare, Cement, Zinc, FBE & Other Linings

Joint Restraint System

- EZD Joint Restraint for DI Pipe 3" - 48"
- EZDTP Joint Restraint Tandem for DI Pipe 3" - 48"
- EZDPTP Joint Restraint for Push-On Joints DI Pipe 3" - 48"
- Ductile Iron Retainer Glands 3" - 30"
- FAR / FAH Flange Adapter for DI Pipe 3" - 48"
- EZFA Restrained Flange Adapter for DI and PVC Pipe 3" - 36"
- EZPVC Joint Restraint for PVC Pipe 3" - 36"
- ULTRA Joint Restraint for PVC Pipe 4" - 12"
- EZPVCPTP Joint Restraint for Push-On Joints PVC Pipe 14" - 36"
- PTPVC Pipe to Pipe Restraint 4" - 48"
- PTPDF Pipe to MJ Fittings Restraint 4" - 48"
- PTPFC Pipe to PVC Fittings Restraint 4" - 12"
- Made in China & USA
- EZ Shield or Shop Coating

Municipal Construction Castings

- Manhole Rings and Cover
- Frames and Grates
- Valve Boxes and Service Boxes
- Water Meter Covers and Boxes
- Cleanout and Monument Boxes
- Detectable Warning Plates
- Extension Rings
- Trench Grates and Tree Grates
- Made in India & USA

Fabrication Products for DI Pipe

- High Hub Flanges Class 150 and 250. 3" - 64"
- Threaded Bell Flanges 3" - 48"
- Anchor Flanges 3" - 60"
- Filler Flanges 4" - 30"

Other Products and Services

- All Thread Rod
- Pipe Lube and Hydraulic Cement
- Socket Clamps and Lugs
- Flange Packs
- OEM Castings



SIP INDUSTRIES
SERAMPORE
SINCE 1960

SIP CORPORATE 8876 Gulf Freeway, Suite 500, Houston, TX 77017

SIP CENTRAL 2900 Patio Drive, Houston, TX 77017

SIP EAST 600 Rayloc Drive, Atlanta, GA 30336

SIP WEST 8333 Almeria Avenue, Fontana, CA 92335

Phone: 877-921-6111 or 713-923-6111 | Fax: 713-923-6114 | www.sipindustries.com | sales@sipindustries.com