



3" - 48" TANDEM RESTRAINTS FOR DI PIPE & FITTINGS

Submittal Information

Project Name / Location:	
Engineer:	
Referenced Specs:	
Distributor / Contractor:	

Optional Specifications

Coating:	Standard Alkyd, Direct To Metal (DTM) Enamel (Black)
	EZ-Shield® Polyester Based Powder Coating (Black)
	Other - Specify:
Bolts, Nuts & Rods:	High Strength Low Alloy Steel (HSLA) In Accordance With ANSI/AWWA C111/A21.11
	Fluoropolymer Corrosion Resistant Coating
	Stainless Steel: Type 304 Type 316
Gaskets:	Other - Specify:
	Standard SBR (Buna-S) In Accordance With ANSI/AWWA C111/A21.11
	Other - Specify:

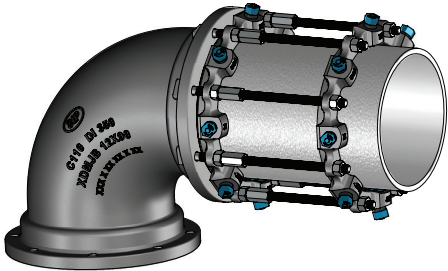

General Specifications

- Material** : Gland, Heat Treated wedges, twist-off nuts and actuating screws are Ductile Iron per ASTM A536 Grade 65-45-12
Coupling nuts are Grade 5 Medium Carbon Steel
- Pressure** : 700 PSI rating for sizes 3"- 8", 600 PSI for sizes 10"-12", 500 PSI for sizes 14"-16", 350 PSI for sizes 18"-24", 300 PSI for sizes 30"-48"
- Dimensions** : Gland complies with all applicable dimensions of, and is compatible with, all mechanical joint sockets of ANSI/AWWA C111/A21.11, C110/A21.10, and C153/A21.53 Standards.
- Installation** : Install in accordance with SIP installation procedures and intent of AWWA C600 / M41.
Pipe ends must be free from defects to allow wedges to properly engage the pipe ends.
Wedge pockets must be free for debris intrusion to allow movement, polyethylene wrap of the restraint is recommended as a prevention.
Per ANSI/AWWA C600 and C111 using DIP conforming to C150/C151, and Steel Pipe 3"-12"
- Deflection** : 5° on sizes 3" - 12", 3° on 14"-24", 2° on 30"-36" and 1° on 42"- 48"
- Coating** : Wedges, twist-off nuts and actuating screws Fluoropolymer coated
- Approvals** : Joint restraints used in the tandem restraint configuration have the following approvals:
Sizes 3" - 24" UL Listed and sizes 3" - 12" FM Approved



Technical Specifications

Select Size	Size	Series Number	DI Pipe OD	All Thread Rod Size	T-Head Bolt	Coupling Nut	Approx. Weight (Lbs)
	3	EZDTP03	3.96	3/8 X 6	3/8 X 4	3/8 X 2 1/8	20
	4	EZDTP04	4.80	3/8 X 12	3/8 X 4 1/2	3/8 X 2 1/4	30
	6	EZDTP06	6.90	3/8 X 12	3/8 X 4 1/2	3/8 X 2 1/4	40
	8	EZDTP08	9.05	3/8 X 12	3/8 X 4 1/2	3/8 X 2 1/4	50
	10	EZDTP10	11.10	3/8 X 12	3/8 X 4 1/2	3/8 X 2 1/4	70
	12	EZDTP12	13.20	3/8 X 12	3/8 X 5	3/8 X 2 1/4	90
	14	EZDTP14	15.30	3/8 X 12	3/8 X 5 1/2	3/8 X 2 1/4	140
	16	EZDTP16	17.40	3/8 X 12	3/8 X 5 1/2	3/8 X 2 1/4	160
	18	EZDTP18	19.50	3/8 X 12	3/8 X 5 1/2	3/8 X 2 1/4	180
	20	EZDTP20	21.60	3/8 X 12	3/8 X 5 1/2	3/8 X 2 1/4	190
	24	EZDTP24	25.80	3/8 X 12	3/8 X 6	3/8 X 2 1/4	295
	30	EZDTP30	32.00	1 X 12	1 X 7 1/2	1 X 2 3/4	520
	36	EZDTP36	38.30	1 X 12	1 X 7 1/2	1 X 2 3/4	615
	42	EZDTP42	44.50	1 1/4 X 12	1 1/4 X 9 1/2	1 1/4 X 3	1120
	48	EZDTP48	50.80	1 1/4 X 12	1 1/4 X 9 1/2	1 1/4 X 3	1360

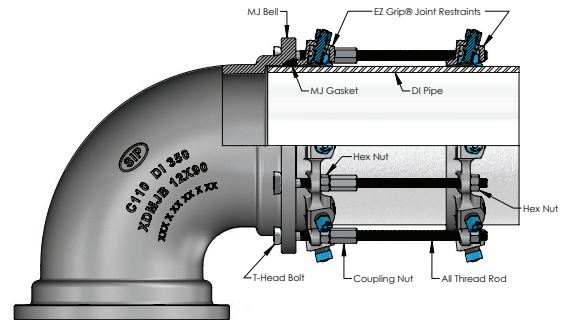

Supporting documentation for the above 'General Specifications' and 'Optional Specifications' are available upon request to review, in addition to Installation Instructions and any requested material samples

Please contact SIP for technical assistance of nonstandard applications and pressures

Please refer to our web page www.sipindustries.com for up to date product data and technical advisories

V 0524-01