

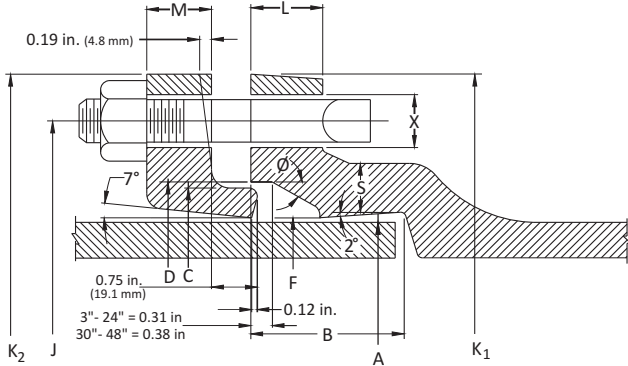

2" - 64" DUCTILE IRON MECHANICAL JOINT FULL BODY FITTINGS

Submittal Information

Project Name / Location:	
Engineer:	
Referenced Specs:	
Distributor / Contractor:	



Optional Specifications

Coating:	Asphaltic Seal Coat <i>In Accordance With ANSI/AWWA C104/A21.4</i>
	Fusion-Bonded Epoxy (FBE) Powder (Red Oxide Color) <i>In Accordance With ANSI/AWWA C116/A21.16</i>
	Arc Zinc <i>In Accordance with ISO 8179-1</i>
	Bare
Other - Specify:	
Lining:	Cement-Mortar - <i>In Accordance With ANSI/AWWA C104/A21.4</i> Single Lined Double Lined Asphalt Coating No Asphalt Coating
	Fusion-Bonded Epoxy (FBE) Powder (Red Oxide Color) <i>In Accordance With ANSI/AWWA C116/A21.16</i>
	Ceramic Epoxy
	Bare
	Other - Specify:
Bolts / Nuts:	Standard High Strength Low Alloy Steel (HSLA) <i>In Accordance With ANSI/AWWA C111/A21.11</i>
	Stainless Steel: Type 304 Type 316
	Other - Specify:
Gaskets:	Standard SBR (Buna-S) <i>In Accordance With ANSI/AWWA C111/A21.11</i>
	Other - Specify:

General Specifications

- Material** : Ductile Iron per ASTM A536
- Pressure** : 350 PSI rating for 2" - 24" sizes, 250 PSI rating for 30" - 48" sizes and 150 PSI rating for 54" - 64" sizes
- Testing** : In accordance with ANSI/AWWA C110/A21.10 and UL, FM requirements
- Laying Length** : In accordance with ANSI/AWWA C110/A21.10
(fittings not listed in ANSI/AWWA have dimensions per SIP design as noted in the catalog)
- Deflection** : 2" - 4" = 8° | 6" = 7° | 8" - 12" = 5° | 14" - 16" = 3 1/2° | 18" - 24" = 3° | 30" - 64" = 2°
- Flanges** : Flanged ends on fittings match ANSI/AWWA C110/A21.10 and ANSI B16.1 class 125 flanges
- Weight** : Are in pounds, unless noted otherwise and do not include accessories, cement lining and coating
- Dimensions** : MJ Bell dimensions meet ANSI/AWWA C111/A21.11 specification. All dimensions are in inches unless noted otherwise.
- Installations** : Per ANSI/AWWA C600 and C111
- Approvals** : 3" - 24" UL Listed | 3" - 16" FM Approved | 3" and higher UL/NSF 61 | 2" and higher NSF/ANSI 61 & 372
Please consult SIP for detail listing and approvals.



Technical Specifications

Select Size	Size	A	B	C	D	F	J	K ₁	K ₂	M	S	L	Ø	X	Bolt		
															No.	Size	Length
	*2	2.50	2.50	3.39	3.50	2.61	4.75	6.25	6.25	0.62	0.44	0.75	28°	3/4	2	3/8	3
	3	3.96	2.50	4.84	4.94	4.06	6.19	7.69	7.69	0.62	0.52	0.94	28°	3/4	4	3/8	3
	4	4.80	2.50	5.92	6.02	4.90	7.50	9.12	9.12	0.75	0.65	1.00	28°	7/8	4	3/4	3 1/2
	6	6.90	2.50	8.02	8.12	7.00	9.50	11.12	11.12	0.88	0.70	1.06	28°	7/8	6	3/4	3 1/2
	8	9.05	2.50	10.17	10.27	9.15	11.75	13.37	13.37	1.00	0.75	1.12	28°	7/8	6	3/4	4
	10	11.10	2.50	12.22	12.34	11.20	14.00	15.69	15.62	1.00	0.80	1.19	28°	7/8	8	3/4	4
	12	13.20	2.50	14.32	14.44	13.30	16.25	17.94	17.88	1.00	0.85	1.25	28°	7/8	8	3/4	4
	14	15.30	3.50	16.40	16.54	15.44	18.75	20.31	20.25	1.25	0.89	1.31	28°	7/8	10	3/4	4 1/2
	16	17.40	3.50	18.50	18.64	17.54	21.00	22.56	22.50	1.31	0.97	1.38	28°	7/8	12	3/4	4 1/2
	18	19.50	3.50	20.60	20.74	19.64	23.25	24.83	24.75	1.38	1.05	1.44	28°	7/8	12	3/4	4 1/2
	20	21.60	3.50	22.70	22.84	21.74	25.50	27.08	27.00	1.44	1.12	1.50	28°	7/8	14	3/4	4 1/2
	24	25.80	3.50	26.90	27.04	25.94	30.00	31.58	31.50	1.56	1.22	1.62	28°	7/8	16	3/4	5
	30	32.00	4.00	33.29	33.46	32.17	36.88	39.12	39.12	2.00	1.50	1.81	20°	1 1/8	20	1	6
	36	38.30	4.00	39.59	39.76	38.47	43.75	46.00	46.00	2.00	1.80	2.00	20°	1 1/8	24	1	6
	42	44.50	4.00	45.79	45.96	44.67	50.62	53.12	53.12	2.00	1.95	2.00	20°	1 1/8	28	1 1/4	6 1/2
	48	50.80	4.00	52.09	52.26	50.97	57.50	60.00	60.00	2.00	2.20	2.00	20°	1 1/8	32	1 1/4	6 1/2
	*54	57.56	4.00	58.82	59.02	57.73	63.20	65.70	65.70	2.00	1.79	2.00	20°	1 1/8	36	1 1/4	6 1/2
	*60	61.61	4.00	62.87	63.07	61.78	67.72	70.22	70.22	2.00	2.00	2.00	20°	1 1/8	36	1 1/4	6 1/2
	*64	65.67	4.00	66.96	67.13	65.84	71.86	74.36	74.36	2.00	2.00	2.00	20°	1 1/8	38	1 1/4	6 1/2

* Not Included In AWWA C110

Please refer to our web page www.sipindustries.com for up to date product data and technical advisories