

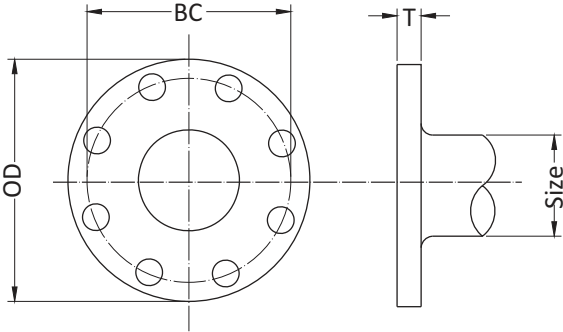

1" - 64" FLANGED FITTINGS ANSI/AWWA C110/A21.10

Submittal Information

Project Name / Location:	
Engineer:	
Referenced Specs:	
Distributor / Contractor:	



Optional Specifications

Coating:	<input type="checkbox"/>	Asphaltic Seal Coat Inside & Prime Coat Red Outside <i>In Accordance With ANSI/AWWA C104/A21.4</i>
	<input type="checkbox"/>	Fusion-Bonded Epoxy (FBE) Powder (Red Oxide Color) <i>In Accordance With ANSI/AWWA C116/A21.16</i>
	<input type="checkbox"/>	Arc Zinc <i>In Accordance with ISO 8179-1</i>
	<input type="checkbox"/>	Bare
	<input type="checkbox"/>	Other - Specify:
Lining:	<input type="checkbox"/>	Cement-Mortar - <i>In Accordance With ANSI/AWWA C104/A21.4</i> <input type="checkbox"/> Single Lined <input type="checkbox"/> Double Lined <input type="checkbox"/> Asphalt Coating <input type="checkbox"/> No Asphalt Coating
	<input type="checkbox"/>	Fusion-Bonded Epoxy (FBE) Powder (Red Oxide Color) <i>In Accordance With ANSI/AWWA C116/A21.16</i>
	<input type="checkbox"/>	Ceramic Epoxy
	<input type="checkbox"/>	Bare
	<input type="checkbox"/>	Other - Specify:
Bolts / Nuts:	<input type="checkbox"/>	Standard Carbon Steel: Type A307
	<input type="checkbox"/>	Stainless Steel: <input type="checkbox"/> Type 304 <input type="checkbox"/> Type 316
	<input type="checkbox"/>	Other - Specify:
Gaskets:	<input type="checkbox"/>	Standard SBR (Buna-S)
	<input type="checkbox"/>	Other - Specify:

General Specifications

- Material** : Ductile Iron per ASTM A536
- Pressure** : 250 PSI rating for 1" - 48" sizes and 150 PSI rating for 54" - 64" sizes (Higher PSI ratings available but gasket dependent)
- Testing** : In accordance with ANSI/AWWA C110/A21.10 and UL, FM requirements
- Laying Length** : 3" - 48" : In accordance with ANSI/AWWA C110/A21.10 | ANSI B16.1
54" - 64" : In accordance with ANSI/AWWA C153/A21.53
(fittings not listed in ANSI/AWWA have dimensions per SIP design as noted in the catalog)
- Drilling** : In accordance with ANSI/AWWA C110/A21.10 | ANSI/AWWA C153/A21.53 | ANSI B16.1 Class 125 Flanges
- Weight** : Are in pounds, unless noted otherwise and do not include accessories, cement lining and coating
- Dimensions** : All dimensions are in inches unless noted otherwise
- Installations** : Per ANSI/AWWA C600 and C111
- Approvals** : 3" - 24" UL Listed | 2" - 24" FM Approved | 3" and higher UL/NSF 61 | 2" and higher NSF/ANSI 61 & 372
Please consult SIP for detail listing and approvals



Technical Specifications

Select Size	Size	O.D.	B.C.	T	Bolt Hole Dia.	Bolt		
						No.	Size	Length
	*1	4.25	3.13	0.44	0.63	4	½	1 ¾
	*1 ½	5.00	3.88	0.56	0.63	4	½	2
	*2	6.00	4.75	0.63	0.75	4	¾	2 ½
	*2 ½	7.00	5.50	0.69	0.75	4	¾	2 ½
	3	7.50	6.00	0.75	0.75	4	¾	2 ½
	4	9.00	7.50	0.94	0.75	8	¾	3
	*5	10.00	8.50	0.94	0.88	8	¾	3
	6	11.00	9.50	1.00	0.88	8	¾	3 ½
	8	13.50	11.75	1.12	0.88	8	¾	3 ½
	10	16.00	14.25	1.19	1.00	12	¾	4
	12	19.00	17.00	1.25	1.00	12	¾	4
	14	21.00	18.75	1.38	1.13	12	1	4 ½
	16	23.50	21.25	1.44	1.13	16	1	4 ½
	18	25.00	22.75	1.56	1.25	16	1 ½	5
	20	27.50	25.00	1.69	1.25	20	1 ½	5
	24	32.00	29.50	1.88	1.38	20	1 ¾	5 ½
	30	38.75	36.00	2.12	1.38	28	1 ¾	6 ½
	36	46.00	42.75	2.38	1.63	32	1 ½	7
	42	53.00	49.50	2.62	1.63	36	1 ½	7 ½
	48	59.50	56.00	2.75	1.63	44	1 ½	8
	*54	66.25	62.75	3.00	2.00	44	1 ¾	8 ½
	*60	73.00	69.25	3.12	2.00	52	1 ¾	9
	*64	80.00	76.00	3.38	2.00	52	1 ¾	9

* Not Included In AWWA C110

Please refer to our web page www.sipindustries.com for up to date product data and technical advisories