



**SIP Industries**  
Quality Manufacturer Since 1960

**Certificate of Compliance : Standard & Heavy-Duty Valve And Service Boxes**

Date	
------	--

SIP certifies that our Standard and Heavy-Duty Valve and Service Boxes are designed, manufactured, and distributed as per the Waterworks industry standards. All castings are tested and traceable by casting markings to the below standards. Please refer to our website [www.sipindustries.com](http://www.sipindustries.com) for up to date product data and technical advisories.

Material : Valve and service boxes are produced with either Gray Iron ASTM A48 CL30/CL35 or Ductile Iron ASTM A536 with standard lengths of 19" – 82".

Standards : Valve boxes are produced to meet the applicable American Association of State Highway and Transportation Officials (AASHTO) provisions.  
Castings are coated with asphaltic bituminous coating with minimum 1.5 mil thickness.

**Series 6000 5 1/4" Shaft Screw Type**

**Series 6100 5 1/4" Shaft Slip Type**

**Series 6200 5 1/4" Shaft Screw 3 Piece**

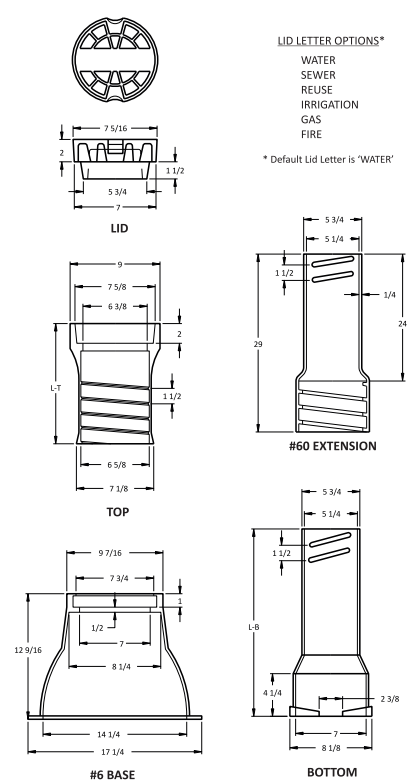
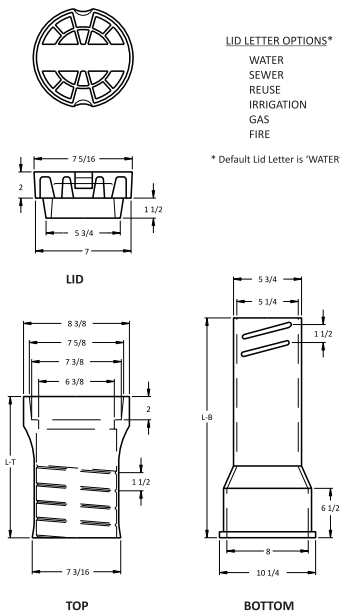
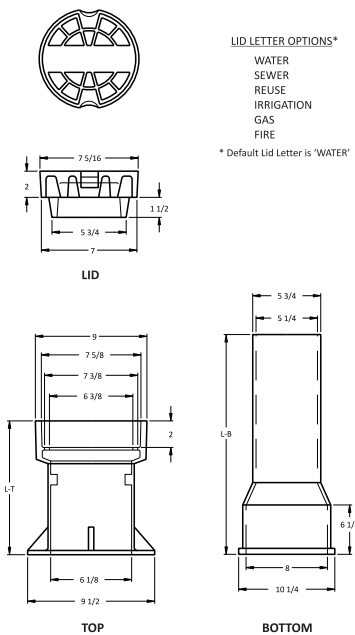

Sincerely,

Roger Johnson  
Director of Technical Services  
[rjohnson@sipindustries.com](mailto:rjohnson@sipindustries.com)

Project Name	
Project Location	
Distributor	
Contractor	



**SIP CORPORATE** 8876 Gulf Freeway, Suite 500, Houston, TX 77017  
**SIP CENTRAL** 2900 Patio Drive, Houston, TX 77017  
**SIP EAST** 600 Rayloc Drive, Atlanta, GA 30336  
**SIP WEST** 8333 Almeria Avenue, Fontana, CA 92335

Phone: 877-921-6111 or 713-923-6111 | Fax: 713-923-6114 | [www.sipindustries.com](http://www.sipindustries.com) | [sales@sipindustries.com](mailto:sales@sipindustries.com)

V 0524-01