



SIP Industries

Quality Manufacturers Since 1960



Full Body MJ Fittings

ANSI/AWWA C110/21.10

V 0524-01

www.sipindustries.com

Toll Free 877-921-6111



★ ★ ★
SIP INDUSTRIES
SERAMPORE
SINCE 1960

TABLE OF CONTENTS

General Terms & Conditions.....	Page : FBMJ02-FBMJ04
General & Technical Specifications.....	Page : FBMJ05
MJ X MJ Bends.....	Page : FBMJ06
MJ X PE Bends.....	Page : FBMJ06
MJ X FLANGE Bends.....	Page : FBMJ07
MJ X MJ Tees.....	Page : FBMJ07-FBMJ09
MJ X FLANGE Tees.....	Page : FBMJ07-FBMJ09
MJ X PE Tees.....	Page : FBMJ07-FBMJ09
MJ Crosses.....	Page : FBMJ07-FBMJ09
MJ X FLANGE Cross.....	Page : FBMJ09
MJ X SWIVEL Hydrant Tees.....	Page : FBMJ10
MJ X Dual Purpose Sleeve.....	Page : FBMJ10
MJ X FLANGE Adapters.....	Page : FBMJ10
MJ Sleeves.....	Page : FBMJ10
MJ X MJ Tangential Tees.....	Page : FBMJ10
MJ X Laterals.....	Page : FBMJ11
MJ X MJ Tapped Tees & Crosses.....	Page : FBMJ11
MJ X MJ Reducers.....	Page : FBMJ12 - FBMJ13
PE X Small End MJ Reducers.....	Page : FBMJ12 - FBMJ13
Large End MJ X PE Reducers.....	Page : FBMJ12 - FBMJ13
MJ X FLANGE Reducers.....	Page : FBMJ12 - FBMJ13
FLANGE X MJ Reducers.....	Page : FBMJ12 - FBMJ13
MJ X ECCENTRIC Reducers.....	Page : FBMJ12 - FBMJ13
MJ Offsets.....	Page : FBMJ13
SWIVEL X SWIVEL Hydrant Ell.....	Page : FBMJ13
SWIVEL X SOLID Hydrant Adapter.....	Page : FBMJ14
SWIVEL Gland.....	Page : FBMJ14
Solid & Tapped CAPS & PLUGS.....	Page : FBMJ14
MJ Full Body Glands.....	Page : FBMJ14

- **All dimensions are in inches unless noted otherwise.**
- **All weights are approximate in pounds unless noted otherwise.**

1. Acceptance. All sales by SIP Industries (Seller) are made pursuant to these Terms and Conditions. Submission of a purchase order to Seller, and/or acceptance of goods delivered by Seller, shall be deemed an acceptance of these Terms and Conditions by Purchaser. Please note that these Terms and Conditions may be modified from time to time; the applicable Terms and Conditions are those posted on SIP's website, www.sipindustries.com, at the time that a purchase order is accepted or an agreement otherwise confirmed. Purchaser's alteration or addition to these Terms and Conditions, as same may be in effect from time to time, is expressly rejected unless accepted in writing by an authorized representative of Seller.

2. Entire Agreement. These Terms and Conditions, together with Seller's price list and Purchaser's purchase order, when accepted by Seller, shall be the entire agreement between Seller and Purchaser. Neither Seller nor Purchaser is relying on any representations, warranties or agreements except as expressly provided in these Terms and Conditions and in an accepted purchase order. To the extent of any conflict between the terms of a purchase order or any other documents submitted by Purchaser, on the one hand, and these Terms and Conditions, on the other, these Terms and Conditions shall govern.

3. Prices. Prices and descriptions of goods stated in Seller's price lists are subject to change without notice. Prices are subject to tariffs, raw material surcharges, labor disputes and shipping surcharges. To submit a purchase order, SIP Industries item numbers and part codes should be included. Seller's quotations are on globally sourced products unless otherwise noted. The ordering party is responsible to specify any required origin as required for end use. Quotations, if provided by Seller, expire sixty (60) days from the date provided unless otherwise agreed in writing.

4. Terms. Invoices are due and payable thirty (30) days from date of shipment, unless otherwise written on the invoice or confirmed in writing by Seller. A five percent (5%) late fee will be charged on all past-due accounts. If it becomes necessary to retain attorneys to collect an account, the Purchaser is liable for Seller's attorney's fees and other costs of collection.

5. FOB point of shipment. All prices are FOB point of shipment, unless otherwise agreed in writing. Seller's responsibility for goods therefore ceases and title passes to the Purchaser at the point of shipment; all claims for damages or losses in transit must be directed to the carrier with copy to Seller within ten (10) days of shipment.

6. Delivery. Seller shall have the right to select the freight carrier unless otherwise agreed. Seller has the right to substitute material with same function and design to accommodate unforeseen delays, shortages or restrictions.

7. Cancellations, Changes and Returns. All cancellations, changes and returns must be accepted in writing by an authorized representative of Seller, otherwise they will not be valid and binding on Seller. Seller will not be responsible for unauthorized returned product. It will be the responsibility of purchaser at their expense to have unauthorized product returned or disposed of. Seller shall not be obligated to accept any cancellation, change or return, but if it does so the following terms shall apply: (i) goods must be returned to Seller's facility, in the same condition in which they were accepted by Purchaser; (ii) a handling charge of thirty-five percent (35%) of the purchase price will be deducted from the credit given to Purchaser; and (iii) shipping charges, if not prepaid by Purchaser, will likewise be deducted from the credit given to Purchaser.

8. Specially Manufactured Goods. Unless otherwise agreed, specially-manufactured goods, including goods designed to the Purchaser's specifications, may not be cancelled or returned once work has begun to design or manufacture the goods unless an agreement is reached and confirmed in writing by Seller, including compensation to Seller for work thus far done with respect to the goods.

9. Delays; Force Majeure. Seller shall not be liable for any expenses, loss or damage resulting from any delay in delivery of goods or other failure of Seller's performance due to fire, floods, acts of god, strikes, labor disputes, labor shortages, riots, accidents, transportation delays or other causes beyond the reasonable control of Seller.

10. Disclaimer regarding weights. All stated weights are approximate and are given for inventory and shipping purposes only.

11. Taxes. Seller's prices do not include sales, excise or other taxes. Purchaser shall pay all such taxes. If Purchaser claims a tax exemption, Purchaser shall provide Seller with the necessary tax-exemption numbers and certificates. If Purchaser aims a tax exemption, Purchaser shall provide Seller with the necessary tax-exemption numbers and certificates. If Seller accepts an exemption but is later required by the taxing authority to pay taxes, Purchaser shall reimburse to Seller the amount of such taxes.

12. Limited Warranty. For a period of one calendar year from the date of shipment, Seller warrants that goods sold and delivered by Seller to Purchaser will conform to the number and type of goods described in the accepted purchase order and that such goods will be free from defects in material and workmanship.

THIS LIMITED WARRANTY IS SELLER'S SOLE AND EXCLUSIVE WARRANTY. SELLER MAKES NO OTHER WARRANTY OF ANY KIND, EXPRESS OR IMPLIED. SELLER DOES NOT WARRANT THAT THE GOODS ARE FIT FOR ANY PARTICULAR PURPOSE. SELLER DOES NOT WARRANT THAT THE GOODS ARE MERCHANTABLE.

13. Product Disclaimers. All tooling required to manufacture products are the property of Seller even if tooling costs are incurred by Purchaser. Seller has the right to change product design, engineering, materials, tooling and processes that do not affect the intended use and application of the product. Seller will notify Purchaser if changes are substantial and may affect the application or appearance of the product. Furthermore, references to Buyer's specifications and similar requirements are only to describe the goods and do not give rise to any representation, warranty or other sales term.

Seller manufactures to industry standards and makes every effort to address applications of its products. Please see current technical advisory at Seller's web site, sipindustries.com, for up to date product support and recommendations. All product dimension, designs, technology, tooling, process, software, innovations, and drawings are considered intellectual property and are owned and confidential to Seller. Purchaser has no rights or privileges to SIP industries intellectual property including product applications without Seller's express written consent.

14. Prompt notice required for Limited Warranty claims. Buyer is responsible for promptly inspecting goods on delivery and notifying Seller, within sixty (60) days of delivery to Buyer, of any nonconformity or defect that would be discovered on a reasonable and customary inspection. Provided that such notice is given and that the warranty claim is made within one year, Seller will provide a replacement or price adjustment, in Seller's discretion, not to exceed the net sales price of the defective product. However, this warranty shall be of no force or effect absent such timely notice. Seller shall not in any event be responsible for labor, removal or installation charges incurred in connection with the replacement of defective goods.

15. Conditions to Limited Warranty. Purchaser shall notify Seller immediately upon discovery of a defect so that Seller may inspect the product in its installed condition. Seller shall not be responsible for defects or failures in goods of which it is not so notified; nor shall Seller be responsible for goods manufactured or sold by other parties or losses or impairments caused by such goods; nor shall Seller be responsible for defects or failure of goods due to improper installation, improper usage, normal or abnormal wear and tear, erosion or corrosion, improper storage, use or maintenance, vandalism, vehicular or other accidents, or storms or other forces beyond the control of the parties. Seller also shall not be responsible for goods that have been damaged by misuse, negligence or accident or that have been altered or repaired by any party other than Seller.

16. Limitation on Liability. In the event any remedy hereunder fails of its essential purpose and monetary damages may be imposed, Seller's liability, whether founded in contract or tort (including negligence), arising out of or resulting from (i) the Purchase Order and resulting contract or the performance or breach thereof, or (ii) the design, manufacture, delivery, sale, repair, replacement or use of the goods, shall not exceed the cost of the goods at issue in the claim. NOTWITHSTANDING ANYTHING CONTAINED HEREIN TO THE CONTRARY, SELLER SHALL NOT BE LIABLE TO PURCHASER OR ANY OTHER PERSON FOR CONSEQUENTIAL, INCIDENTAL, SPECIAL, EXEMPLARY, PUNITIVE OR OTHER INDIRECT DAMAGES, INCLUDING, WITHOUT LIMITATION, LOSS OF PROFITS, RECALL-RELATED EXPENSES, AND LOSS OF USE OF THE GOODS.

17. Purchaser specifications. If Seller has designed the goods using information provided by Purchaser, Seller shall not be responsible for design errors resulting from inaccurate or incomplete information supplied by Purchaser. If

Purchaser has provided specifications or a model or sample from which a good is designed and manufactured, Seller shall not be responsible for any defect, error or inadequacy provided that the good is designed or manufactured in compliance with Purchaser's specifications, model or sample.

18. Solvency and Security Interest. By submitting a Purchase Order, Buyer represents to Seller that Buyer is solvent and capable of timely fulfilling its payment and other obligations to Seller. Until the goods and any other indebtedness of Buyer have been paid in full, Buyer, its agents any successors: (i) will hold the goods subject to a security interest in favor of Seller allowing for the right or re-possession by Seller to the extent permitted by applicable law, (ii) will not alter, remove, destroy, or damage any identifying mark on the goods or their packaging, and (iii) will keep the goods separate from any other products.

19. Governing law; venue. All sales shall be governed by the law of the state of Texas. In the event that a lawsuit is filed between the parties on any claim arising out of or in connection with such sales, Seller and Purchaser agree that exclusive venue and jurisdiction shall be in the state or federal courts of Harris County, Texas.

20. Attorney's fees and costs. In the event of litigation between the parties with respect to the sale of goods, the prevailing party shall be entitled to recover its reasonable attorney's fees and costs, including expert witness fees.

3" - 64" DUCTILE IRON MECHANICAL JOINT FULL BODY FITTINGS

General Specifications

- Material** : Ductile Iron per ASTM A536
- Pressure** : 350 PSI rating for 2" - 24" sizes, 250 PSI rating for 30" - 48" sizes and 150 PSI rating for 54" - 64" sizes
- Testing** : In accordance with ANSI/AWWA C110/A21.10 and UL, FM requirements
- Laying Length** : In accordance with ANSI/AWWA C110/A21.10
(fittings not listed in ANSI/AWWA have dimensions per SIP design as noted in the catalog)
- Deflection** : 2" - 4" = 8° | 6" = 7° | 8" - 12" = 5° | 14" - 16" = 3 ½° | 18" - 24" = 3° | 30" - 64" = 2°
- Flanges** : Flanged ends on fittings match ANSI/AWWA C110/A21.10 and ANSI B16.1 class 125 flanges
- Gaskets** : SBR in accordance with ANSI/AWWA C111/A21.11 (see fittings accessories catalog)
- T-Bolts / Nuts** : Low alloy steel in accordance with ANSI/AWWA C111/A21.11 (see fittings accessories catalog)
- Cement Lining** : In accordance with ANSI/AWWA C104/A21.4
- Coating** : Asphaltic seal coat inside and out in accordance with ANSI/AWWA C104/A21.4 and referenced in ANSI/AWWA C110/A21.10 and also available in Fusion-Bonded epoxy (FBE) power coated oxide red color in accordance with the ANSI/AWWA C116/A21.16
- Weight** : Are in pounds, unless noted otherwise and do not include accessories, cement lining and coating
- Dimensions** : All dimensions are in inches unless noted otherwise.
- Installations** : Per ANSI/AWWA C600 and C111 using DIP conforming to C150/C151 and PVC pipe conforming to C900
- Approvals** : 3" - 24" UL Listed | 3" - 24" FM Approved | 3" and higher UL/NSF Standards 61 | 3" and higher NSF/ANSI Standards 61 Approved for Drinking Water. Please consult SIP for detail listing and approvals.

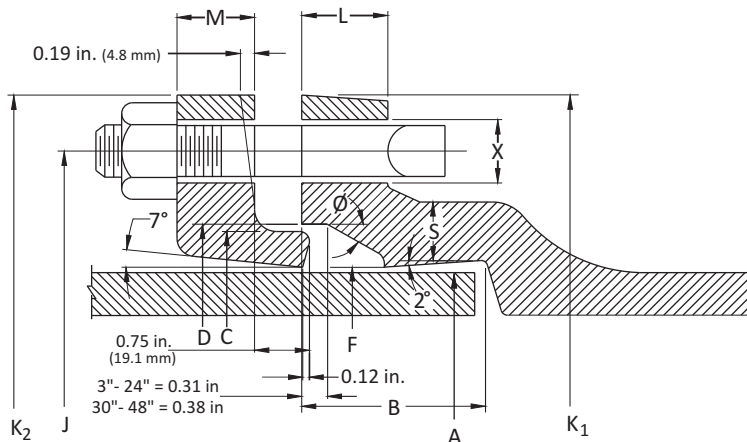

Certified to NSF/ANSI 61 & 372



ANSI/NSF 61 DRINKING WATER SYSTEM COMPONENTS

Technical Specifications

SIZE	A	B	C	D	F	J	K ₁	K ₂	M	S	L	Ø	X	BOLTS		
														NO.	SIZE	LENGTH
*2	2.50	2.50	3.39	3.50	2.61	4.75	6.25	6.25	0.62	0.44	0.75	28°	¾	2	⅝	3
3	3.96	2.50	4.84	4.94	4.06	6.19	7.69	7.69	0.62	0.52	0.94	28°	¾	4	⅝	3
4	4.80	2.50	5.92	6.02	4.90	7.50	9.12	9.12	0.75	0.65	1.00	28°	⅞	4	¾	3 ½
6	6.90	2.50	8.02	8.12	7.00	9.50	11.12	11.12	0.88	0.70	1.06	28°	⅞	6	¾	3 ½
8	9.05	2.50	10.17	10.27	9.15	11.75	13.37	13.37	1.00	0.75	1.12	28°	⅞	6	¾	4
10	11.10	2.50	12.22	12.34	11.20	14.00	15.69	15.62	1.00	0.80	1.19	28°	⅞	8	¾	4
12	13.20	2.50	14.32	14.44	13.30	16.25	17.94	17.88	1.00	0.85	1.25	28°	⅞	8	¾	4
14	15.30	3.50	16.40	16.54	15.44	18.75	20.31	20.25	1.25	0.89	1.31	28°	⅞	10	¾	4 ½
16	17.40	3.50	18.50	18.64	17.54	21.00	22.56	22.50	1.31	0.97	1.38	28°	⅞	12	¾	4 ½
18	19.50	3.50	20.60	20.74	19.64	23.25	24.83	24.75	1.38	1.05	1.44	28°	⅞	12	¾	4 ½
20	21.60	3.50	22.70	22.84	21.74	25.50	27.08	27.00	1.44	1.12	1.50	28°	⅞	14	¾	4 ½
24	25.80	3.50	26.90	27.04	25.94	30.00	31.58	31.50	1.56	1.22	1.62	28°	⅞	16	¾	5
30	32.00	4.00	33.29	33.46	32.17	36.88	39.12	39.12	2.00	1.50	1.81	20°	1 ⅛	20	1	6
36	38.30	4.00	39.59	39.76	38.47	43.75	46.00	46.00	2.00	1.80	2.00	20°	1 ⅛	24	1	6
42	44.50	4.00	45.79	45.96	44.67	50.62	53.12	53.12	2.00	1.95	2.00	20°	1 ⅜	28	1 ¼	6 ½
48	50.80	4.00	52.09	52.26	50.97	57.50	60.00	60.00	2.00	2.20	2.00	20°	1 ⅜	32	1 ¼	6 ½

NB : Fittings & Dimensions for Size 54, 60 & 64 available on request only.

All dimensions are in inches unless noted otherwise.

All weights are approximate in pounds unless noted otherwise.

* not included in AWWA C110

MJ X MJ BENDS

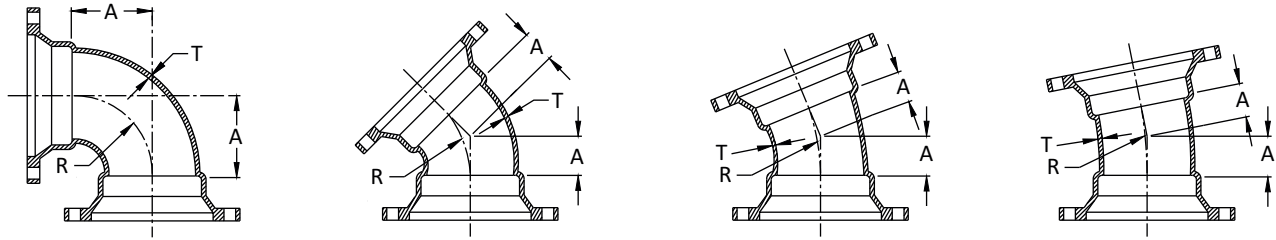

MJ X MJ		90° BENDS (¼)				45° BENDS (⅛)			22.5° BENDS (⅙)			11.25° BENDS (⅓₂)		
SIZE	T	A	R	WT	A	R	WT	A	R	WT	A	R	WT	
*2	0.39	3.25	2.25	16	1.80	1.96	14	1.80	4.02	14	1.80	8.12	14	
3	0.48	5.50	4.00	35	3.00	3.62	30	3.00	7.56	30	3.00	15.25	30	
4	0.52	6.50	4.50	55	4.00	4.81	50	4.00	10.06	50	4.00	20.31	50	
6	0.55	8.00	6.00	85	5.00	7.25	75	5.00	15.06	75	5.00	30.50	75	
8	0.60	9.00	7.00	125	5.50	8.44	110	5.50	17.62	110	5.50	35.50	110	
10	0.68	11.00	9.00	190	6.50	10.88	155	6.50	22.62	160	6.50	45.69	160	
12	0.75	12.00	10.00	255	7.50	13.25	215	7.50	27.62	220	7.50	55.81	220	
14	0.66	14.00	11.50	340	7.50	12.06	270	7.50	25.12	275	7.50	50.75	275	
16	0.70	15.00	12.50	430	8.00	13.25	340	8.00	27.62	345	8.00	55.81	345	
18	0.75	16.50	14.00	545	8.50	14.50	420	8.50	30.19	430	8.50	60.94	430	
20	0.80	18.00	15.50	680	9.50	16.88	530	9.50	35.19	535	9.50	71.06	540	
24	0.89	22.00	18.50	1025	11.00	18.12	755	11.00	37.69	765	11.00	76.12	770	
30	1.03	25.00	21.50	1690	15.00	27.75	1380	15.00	57.81	1400	15.00	116.75	1410	
36	1.15	28.00	24.50	2475	18.00	35.00	2095	18.00	72.88	2135	18.00	147.25	2145	
42	1.28	31.00	27.50	3410	21.00	42.25	2955	21.00	88.00	3020	21.00	117.69	3035	
48	1.42	34.00	30.50	4595	24.00	49.50	4080	24.00	103.06	4170	24.00	208.12	4190	

MJ X PE BENDS

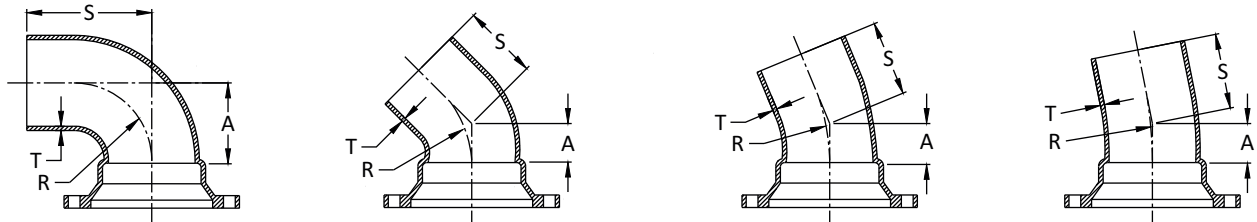

MJ X PE		90° BENDS (¼)				45° BENDS (⅛)				22.5° BENDS (⅙)				11.25° BENDS (⅓₂)			
SIZE	T	A	S	R	WT	A	S	R	WT	A	S	R	WT	A	S	R	WT
3	0.48	5.50	13.50	4.00	35	3.00	11.00	3.62	30	3.00	11.00	7.56	30	3.00	11.00	15.25	30
4	0.52	6.50	14.50	4.50	50	4.00	12.00	4.81	45	4.00	12.00	10.06	45	4.00	12.00	20.31	45
6	0.55	8.00	16.00	6.00	80	5.00	13.00	7.25	70	5.00	13.00	15.06	70	5.00	13.00	30.50	70
8	0.60	9.00	17.00	7.00	120	5.50	13.50	8.44	105	5.50	13.50	17.62	105	5.50	13.50	35.50	105
10	0.68	11.00	19.00	9.00	190	6.50	14.50	10.88	155	6.50	14.50	22.62	160	6.50	14.50	45.69	160
12	0.75	12.00	20.00	10.00	255	7.50	15.50	13.25	215	7.50	15.50	27.62	220	7.50	15.50	55.81	220
14	0.66	14.00	22.00	11.50	325	7.50	15.50	12.06	255	7.50	15.50	25.12	260	7.50	15.50	50.75	260
16	0.70	15.00	23.00	12.50	410	8.00	16.00	13.25	320	8.00	16.00	27.62	325	8.00	16.00	55.81	325
18	0.75	16.50	24.50	14.00	520	8.50	16.50	14.50	395	8.50	16.50	30.19	405	8.50	16.50	60.94	405
20	0.80	18.00	26.00	15.50	650	9.50	17.50	16.88	500	9.50	17.50	35.19	505	9.50	17.50	71.06	510
24	0.89	22.00	30.00	18.50	985	11.00	19.00	18.12	715	11.00	19.00	37.69	725	11.00	19.00	76.12	730
30	1.03	25.00	33.00	21.50	1585	15.00	23.00	27.75	1275	15.00	23.00	57.81	1295	15.00	23.00	116.75	1305
36	1.15	28.00	36.00	24.50	2310	18.00	26.00	35.00	1930	18.00	26.00	72.88	1970	18.00	26.00	147.25	1980
42	1.28	31.00	39.00	27.50	3200	21.00	29.00	42.25	2745	21.00	29.00	88.00	2810	21.00	29.00	177.69	2825
48	1.42	34.00	42.00	30.50	4330	24.00	32.00	49.50	3815	24.00	32.00	103.06	3905	24.00	32.00	208.12	3925

* not included in AWWA C110

All dimensions are in inches unless noted otherwise.

All weights are approximate in pounds unless noted otherwise.

MJ X FLANGE BENDS*

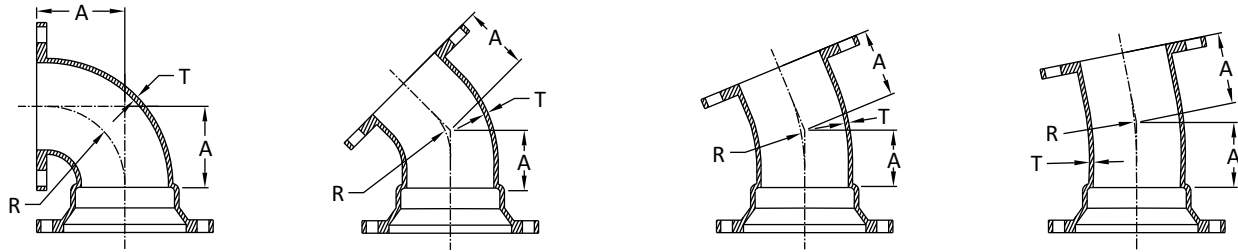

MJ X FLANGE		90° BENDS (¼)			45° BENDS (⅛)			22.5° BENDS (⅙)			11.25° BENDS (⅓)		
SIZE	T	A	R	WT	A	R	WT	A	R	WT	A	R	WT
4	0.52	6.50	4.50	39	4.00	4.81	46	4.00	10.06	46	4.00	20.31	46
6	0.55	8.00	6.00	77	5.00	7.25	71	5.00	15.06	71	5.00	30.50	71
8	0.60	9.00	7.00	118	5.50	8.44	106	5.50	17.62	106	5.50	35.50	106
10	0.68	11.00	9.00	179	6.50	10.88	157	6.50	22.62	157	6.50	45.69	157
12	0.75	12.00	10.00	245	7.50	13.25	218	7.50	27.62	218	7.50	55.81	218
16	0.70	15.00	12.50	467	8.00	13.25	359	8.00	27.62	359	8.00	55.81	359
18	0.75	16.50	14.00	579	8.50	14.50	425	8.50	30.19	425	8.50	60.94	425
20	0.80	18.00	15.50	746	9.50	16.88	544	9.50	35.19	578	9.50	71.06	578
24	0.89	22.00	18.50	1152	11.00	18.12	803	11.00	37.69	803	11.00	76.12	803

TEES : MJ X MJ, MJ X FLANGE, MJ X PLAIN END & CROSSES

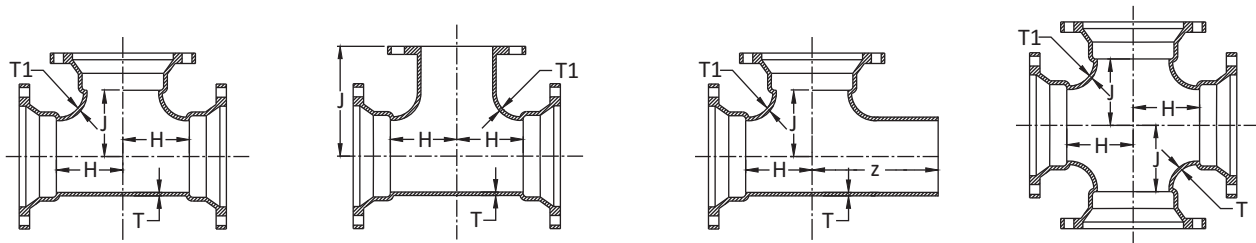

TEES & CROSSES			TEES : MJ X MJ			TEES : MJ X FE*			TEES : MJ X PE				MJ CROSSES		
SIZE	T	T1	H	J	WT	H	J	WT	H	J	Z	WT	H	J	WT
*2 X 2	0.39	0.39	3.25	3.25	22	---	---	---	---	---	---	---	---	---	---
*3 X 2	0.48	0.39	3.50	3.50	45	---	---	---	---	---	---	---	---	---	---
3 X 3	0.48	0.48	5.50	5.50	55	5.50	5.50	---	5.50	5.50	13.50	55	5.50	5.50	70
*4 X 2	0.52	0.39	4.00	4.00	59	4.80	4.80	53	---	---	---	---	---	---	---
4 X 3	0.52	0.48	6.50	6.50	75	6.50	6.50	---	6.50	6.50	14.50	70	6.50	6.50	90
4 X 4	0.52	0.52	6.50	6.50	80	6.50	6.50	80	6.50	6.50	14.50	75	6.50	6.50	105
*4 X 4 X 6	0.52	0.55	8.00	8.00	117	8.00	8.00	105	---	---	---	---	---	---	---
*6 X 2	0.55	0.39	8.00	8.00	81	---	---	---	---	---	---	---	---	---	---
6 X 3	0.55	0.48	8.00	8.00	110	8.00	8.00	---	8.00	8.00	16.00	105	8.00	8.00	125
6 X 4	0.55	0.52	8.00	8.00	115	8.00	8.00	115	8.00	8.00	16.00	110	8.00	8.00	140
6 X 6	0.55	0.55	8.00	8.00	125	8.00	8.00	128	8.00	8.00	16.00	120	8.00	8.00	160
*6 X 6 X 8	0.55	0.60	9.00	9.00	189	---	---	---	---	---	---	---	---	---	---
*8 X 2	0.60	0.39	9.00	9.00	127	---	---	---	---	---	---	---	---	---	---
*8 X 3	0.60	0.48	9.00	9.00	156	---	---	---	---	---	---	---	---	---	---
8 X 4	0.60	0.52	9.00	9.00	165	9.00	9.00	160	9.00	9.00	17.00	160	9.00	9.00	185
8 X 6	0.60	0.55	9.00	9.00	175	9.00	9.00	170	9.00	9.00	17.00	170	9.00	9.00	205
8 X 8	0.60	0.60	9.00	9.00	185	9.00	9.00	177	9.00	9.00	17.00	180	9.00	9.00	235
10 X 4	0.68	0.52	11.00	11.00	235	11.00	11.00	230	11.00	11.00	19.00	235	11.00	11.00	260
10 X 6	0.68	0.55	11.00	11.00	250	11.00	11.00	228	11.00	11.00	19.00	250	11.00	11.00	285
10 X 8	0.68	0.60	11.00	11.00	260	11.00	11.00	250	11.00	11.00	19.00	260	11.00	11.00	310
10 X 10	0.80	0.80	11.00	11.00	310	11.00	11.00	261	11.00	11.00	19.00	310	11.00	11.00	380
12 X 4	0.75	0.52	12.00	12.00	315	12.00	12.00	310	12.00	12.00	20.00	315	12.00	12.00	340

Con't

* not included in AWWA C110

All dimensions are in inches unless noted otherwise.

All weights are approximate in pounds unless noted otherwise.

TEES : MJ X MJ, MJ X FLANGE, MJ X PLAIN END & CROSSES (Con't)

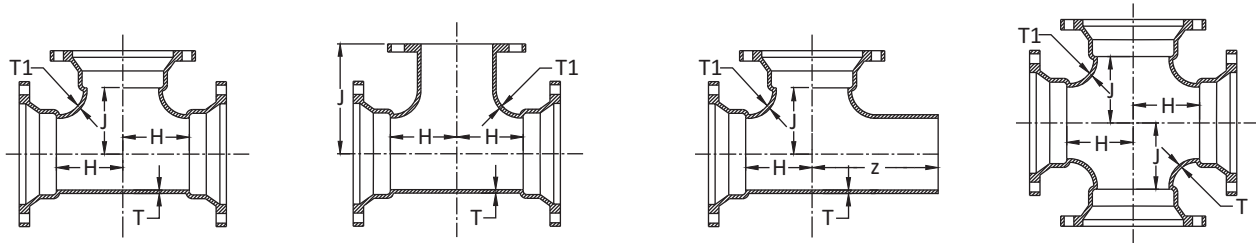

TEES & CROSSES			TEES : MJ X MJ			TEES : MJ X FE*			TEES : MJ X PE				MJ CROSSES		
SIZE	T	T1	H	J	WT	H	J	WT	H	J	Z	WT	H	J	WT
12 X 6	0.39	0.55	12.00	12.00	325	12.00	12.00	324	12.00	12.00	20.00	325	12.00	12.00	360
12 X 8	0.48	0.60	12.00	12.00	340	12.00	12.00	332	12.00	12.00	20.00	340	12.00	12.00	385
12 X 10	0.48	0.80	12.00	12.00	390	12.00	12.00	369	12.00	12.00	20.00	390	12.00	12.00	460
12 X 12	0.52	0.87	12.00	12.00	410	12.00	12.00	400	12.00	12.00	20.00	410	12.00	12.00	495
14 X 6	0.52	0.55	14.00	14.00	435	14.00	14.00	487	14.00	14.00	22.00	420	14.00	14.00	475
14 X 8	0.52	0.60	14.00	14.00	450	14.00	14.00	502	14.00	14.00	22.00	435	14.00	14.00	500
14 X 10	0.52	0.68	14.00	14.00	465	14.00	14.00	---	14.00	14.00	22.00	450	14.00	14.00	540
14 X 12	0.55	0.75	14.00	14.00	495	14.00	14.00	---	14.00	14.00	22.00	475	14.00	14.00	585
14 X 14	0.55	0.66	14.00	14.00	520	14.00	14.00	485	14.00	14.00	22.00	500	14.00	14.00	635
*16 X 4	0.55	0.52	15.00	15.00	530	15.00	15.00	578	---	---	---	---	---	---	---
16 X 6	0.55	0.55	15.00	15.00	540	15.00	15.00	607	15.00	15.00	23.00	520	15.00	15.00	575
16 X 8	0.55	0.60	15.00	15.00	550	15.00	15.00	616	15.00	15.00	23.00	530	15.00	15.00	605
16 X 10	0.60	0.68	15.00	15.00	570	15.00	15.00	638	15.00	15.00	23.00	550	15.00	15.00	645
16 X 12	0.60	0.75	15.00	15.00	590	15.00	15.00	650	15.00	15.00	23.00	570	15.00	15.00	685
16 X 14	0.60	0.66	15.00	15.00	620	15.00	15.00	---	15.00	15.00	23.00	600	15.00	15.00	735
16 X 16	0.60	0.70	15.00	15.00	650	15.00	15.00	732	15.00	15.00	23.00	625	15.00	15.00	790
18 X 6	0.60	0.55	13.00	15.50	590	13.00	15.50	667	13.00	15.50	21.00	565	13.00	15.50	625
18 X 8	0.68	0.60	13.00	15.50	605	13.00	15.50	678	13.00	15.50	21.00	580	13.00	15.50	655
18 X 10	0.68	0.68	13.00	15.50	620	13.00	15.50	---	13.00	15.50	21.00	595	13.00	15.50	685
18 X 12	0.68	0.75	13.00	15.50	640	13.00	15.50	706	13.00	15.50	21.00	615	13.00	15.50	725
18 X 14	0.80	0.66	16.50	16.50	755	16.50	16.50	---	16.50	16.50	24.50	730	16.50	16.50	870
18 X 16	0.75	0.70	16.50	16.50	785	16.50	16.50	---	16.50	16.50	24.50	760	16.50	16.50	930
18 X 18	0.75	0.75	16.50	16.50	820	16.50	16.50	917	16.50	16.50	24.50	795	16.50	16.50	995
20 X 6	0.80	0.55	14.00	17.00	725	14.00	17.00	710	14.00	17.00	22.00	695	14.00	17.00	760
20 X 8	0.80	0.60	14.00	17.00	735	14.00	17.00	735	14.00	17.00	22.00	705	14.00	17.00	790
20 X 10	0.80	0.68	14.00	17.00	755	14.00	17.00	---	14.00	17.00	22.00	725	14.00	17.00	820
20 X 12	0.80	0.75	14.00	17.00	775	14.00	17.00	769	14.00	17.00	22.00	745	14.00	17.00	860
20 X 14	0.80	0.66	14.00	17.00	795	14.00	17.00	---	14.00	17.00	22.00	765	14.00	17.00	905
20 X 16	0.80	0.70	18.00	18.00	945	18.00	18.00	1077	18.00	18.00	26.00	915	18.00	18.00	1085
20 X 18	0.80	0.75	18.00	18.00	985	18.00	18.00	---	18.00	18.00	26.00	950	18.00	18.00	1155
20 X 20	0.80	0.80	18.00	18.00	1020	18.00	18.00	1169	18.00	18.00	26.00	990	18.00	18.00	1230
24 X 6	0.89	0.55	15.00	19.00	985	15.00	19.00	1128	15.00	19.00	23.00	945	15.00	19.00	1025
24 X 8	0.89	0.60	15.00	19.00	1000	15.00	19.00	1142	15.00	19.00	23.00	960	15.00	19.00	1045
24 X 10	0.89	0.68	15.00	19.00	1020	15.00	19.00	1151	15.00	19.00	23.00	980	15.00	19.00	1085
24 X 12	0.89	0.75	15.00	19.00	1030	15.00	19.00	1168	15.00	19.00	23.00	990	15.00	19.00	1110
24 X 14	0.89	0.66	15.00	19.00	1055	15.00	19.00	1203	15.00	19.00	23.00	1,015	15.00	19.00	1155
24 X 16	0.89	0.70	15.00	19.00	1075	15.00	19.00	1220	15.00	19.00	23.00	1,035	15.00	19.00	1200
24 X 18	0.89	0.75	22.00	22.00	1400	22.00	22.00	1638	22.00	22.00	30.00	1,360	22.00	22.00	1590
24 X 20	0.89	0.80	22.00	22.00	1450	22.00	22.00	1708	22.00	22.00	30.00	1,410	22.00	22.00	1675
24 X 24	0.89	0.89	22.00	22.00	1535	22.00	22.00	1796	22.00	22.00	30.00	1,490	22.00	22.00	1835
30 X 6	1.03	0.55	18.00	23.00	1730	18.00	23.00	1708	18.00	23.00	26.00	1,615	18.00	23.00	1770
30 X 8	1.03	0.60	18.00	23.00	1745	18.00	23.00	1724	18.00	23.00	26.00	1,630	18.00	23.00	1795
30 X 10	1.03	0.68	18.00	23.00	1760	18.00	23.00	1615	18.00	23.00	26.00	1,645	18.00	23.00	1830
30 X 12	1.03	0.75	18.00	23.00	1780	18.00	23.00	1640	18.00	23.00	26.00	1,665	18.00	23.00	1865
30 X 14	1.03	0.66	18.00	23.00	1800	18.00	23.00	---	18.00	23.00	26.00	1,685	18.00	23.00	1905
30 X 16	1.03	0.70	18.00	23.00	1820	18.00	23.00	---	18.00	23.00	26.00	1,705	18.00	23.00	1950
30 X 18	1.03	0.75	18.00	23.00	1845	18.00	23.00	---	18.00	23.00	26.00	1,730	18.00	23.00	2000
30 X 20	1.03	0.80	18.00	23.00	1875	18.00	23.00	---	18.00	23.00	26.00	1,760	18.00	23.00	2060

* not included in AWWA C110

Con't

All dimensions are in inches unless noted otherwise.

All weights are approximate in pounds unless noted otherwise.

TEES : MJ X MJ, MJ X FLANGE, MJ X PLAIN END & CROSSES (Con't)

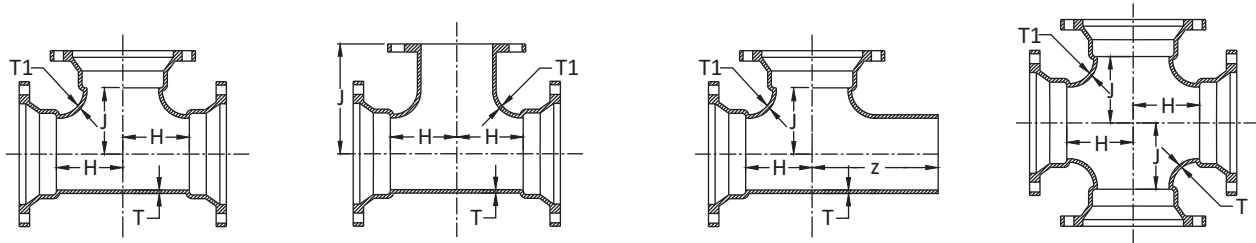

TEES & CROSSES			TEES : MJ X MJ			TEES : MJ X FE*			TEES : MJ X PE				MJ CROSSES		
SIZE	T	T1	H	J	WT	H	J	WT	H	J	Z	WT	H	J	WT
30 X 24	1.03	0.89	25.00	25.00	2400	25.00	25.00	---	25.00	25.00	33.00	2,280	25.00	25.00	2675
30 X 30	1.03	1.03	25.00	25.00	2595	25.00	25.00	3081	25.00	25.00	33.00	2,480	25.00	25.00	3075
*36 X 6	1.15	0.55	20.00	26.00	2510	20.00	26.00	2400	---	---	---	---	---	---	---
36 X 8	1.15	0.60	20.00	26.00	2520	20.00	26.00	2495	20.00	26.00	28.00	2,345	20.00	26.00	2565
36 X 10	1.15	0.68	20.00	26.00	2535	20.00	26.00	2375	20.00	26.00	28.00	2,360	20.00	26.00	2600
36 X 12	1.15	0.75	20.00	26.00	2550	20.00	26.00	2391	20.00	26.00	28.00	2,375	20.00	26.00	2630
36 X 14	1.15	0.66	20.00	26.00	2570	20.00	26.00	---	20.00	26.00	28.00	2,395	20.00	26.00	2665
36 X 16	1.15	0.70	20.00	26.00	2585	20.00	26.00	2405	20.00	26.00	28.00	2,410	20.00	26.00	2705
36 X 18	1.15	0.75	20.00	26.00	2610	20.00	26.00	---	20.00	26.00	28.00	2,435	20.00	26.00	2750
36 X 20	1.15	0.80	20.00	26.00	2635	20.00	26.00	---	20.00	26.00	28.00	2,460	20.00	26.00	2805
36 X 24	1.15	0.89	20.00	26.00	2690	20.00	26.00	2468	20.00	26.00	28.00	2,515	20.00	26.00	2910
36 X 30	1.15	1.03	28.00	28.00	3545	28.00	28.00	3150	28.00	28.00	36.00	3,365	28.00	28.00	3965
36 X 36	1.15	1.15	28.00	28.00	3745	28.00	28.00	---	28.00	28.00	36.00	3,565	28.00	28.00	4370
42 X 12	1.28	0.75	23.00	30.00	3555	23.00	30.00	---	23.00	30.00	31.00	3,335	23.00	30.00	3640
42 X 14	1.28	0.66	23.00	30.00	3575	23.00	30.00	---	23.00	30.00	31.00	3,355	23.00	30.00	3675
42 X 16	1.28	0.70	23.00	30.00	3595	23.00	30.00	---	23.00	30.00	31.00	3,375	23.00	30.00	3715
42 X 18	1.28	0.75	23.00	30.00	3615	23.00	30.00	---	23.00	30.00	31.00	3,395	23.00	30.00	3755
42 X 20	1.28	0.80	23.00	30.00	3640	23.00	30.00	---	23.00	30.00	31.00	3,420	23.00	30.00	3810
42 X 24	1.28	0.89	23.00	30.00	3690	23.00	30.00	---	23.00	30.00	31.00	3,470	23.00	30.00	3910
42 X 30	1.28	1.03	31.00	31.00	4650	31.00	31.00	---	31.00	31.00	39.00	4,425	31.00	31.00	5040
42 X 36	1.78	1.58	31.00	31.00	6075	31.00	31.00	---	31.00	31.00	39.00	5,850	31.00	31.00	6655
42 X 42	1.78	1.78	31.00	31.00	6320	31.00	31.00	---	31.00	31.00	39.00	6,095	31.00	31.00	7145
48 X 12	1.42	0.75	26.00	34.00	4870	26.00	34.00	---	26.00	34.00	34.00	4,580	26.00	34.00	4955
48 X 14	1.42	0.66	26.00	34.00	4885	26.00	34.00	---	26.00	34.00	34.00	4,595	26.00	34.00	4985
48 X 16	1.42	0.70	26.00	34.00	4905	26.00	34.00	---	26.00	34.00	34.00	4,615	26.00	34.00	5025
48 X 18	1.42	0.75	26.00	34.00	4925	26.00	34.00	---	26.00	34.00	34.00	4,635	26.00	34.00	5065
48 X 20	1.42	0.80	26.00	34.00	4950	26.00	34.00	---	26.00	34.00	34.00	4,660	26.00	34.00	5115
48 X 24	1.42	0.89	26.00	34.00	4995	26.00	34.00	4979	26.00	34.00	34.00	4,705	26.00	34.00	5210
48 X 30	1.42	1.03	26.00	34.00	5140	26.00	34.00	---	26.00	34.00	34.00	4,855	26.00	34.00	5495
48 X 36	1.42	1.15	34.00	34.00	6280	34.00	34.00	---	34.00	34.00	42.00	5,995	34.00	34.00	6790
48 X 42	1.96	1.78	34.00	34.00	8130	34.00	34.00	---	34.00	34.00	42.00	7,845	34.00	34.00	8815
48 X 48	1.96	1.96	34.00	34.00	8420	34.00	34.00	---	34.00	34.00	42.00	8,135	34.00	34.00	9380
*48X36X48	1.42	1.15	34.00	34.00	6280	34.00	34.00	---	---	---	---	---	---	---	---

CROSS : MJ X FLANGE*

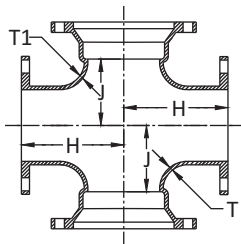

SIZE	T	T1	J	H	WT
6 X 6	0.55	0.55	8.00	8.00	142
8 X 4	0.60	0.52	9.00	9.00	179
8 X 6	0.60	0.55	9.00	9.00	186
8 X 8	0.60	0.60	9.00	9.00	217
10 X10	0.80	0.80	11.00	11.00	356
12 X 6	0.75	0.55	12.00	12.00	343
12 X 8	0.75	0.60	12.00	12.00	366
12 X 12	0.87	0.87	12.00	12.00	490
16 X 8	0.70	0.60	15.00	15.00	587
16 X 16	0.70	0.70	15.00	15.00	771
24 X 16	0.89	0.70	19.00	15.00	990
30 X 10	1.03	0.68	23.00	18.00	1625
36 X 30	1.15	1.03	28.00	28.00	3150

All dimensions are in inches unless noted otherwise.

All weights are approximate in pounds unless noted otherwise.

* not included in AWWA C110

MJ X SWIVEL HYDRANT TEES*

W/SWIVEL GLANDS

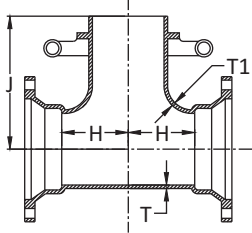

SIZE	T	T1	H	J	WT
6 X 6	0.55	0.55	8.00	10.50	152
8 X 6	0.60	0.55	9.00	11.50	205
8 X 8	0.60	0.60	9.00	11.50	213
10 X 6	0.68	0.55	11.00	13.50	269
12 X 6	0.75	0.55	12.00	14.50	342
16 X 6	0.70	0.55	15.00	17.50	621
16 X 8	0.70	0.60	15.00	17.50	654
20 X 6	0.80	0.55	14.00	19.50	830
30 X 6	1.03	0.55	18.00	24.50	2078

MJ X DUAL PURPOSE SLEEVES*

W/OVERSIZE GLANDS

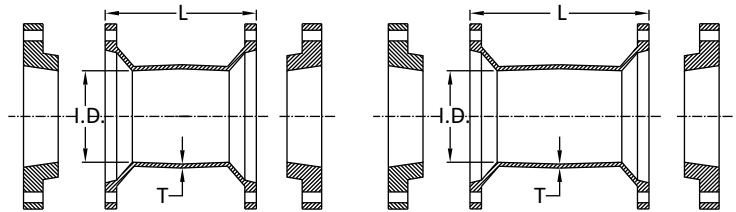

MJ DUAL PURPOSE SLEEVES				SHORT		LONG	
SIZE	PIPE SIZE	T	I.D.	L	WT	L	WT
4	4.80 - 5.00	0.52	5.10	7.50	37	12.00	38
6	6.90 - 7.10	0.55	7.20	7.50	48	12.00	69
8	9.05 - 9.30	0.60	9.40	7.50	70	12.00	90
10	11.10 - 11.40	0.68	11.50	7.50	86	12.00	121
12	13.20 - 13.50	0.75	13.60	7.50	118	12.00	153
16	17.40 - 17.80	0.70	17.94	---	---	15.00	242

ADAPTER : MJ X FLANGE

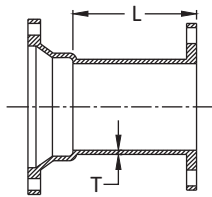

SIZE	L	T	WT
3	8.00	0.48	30
4	8.00	0.52	40
6	8.00	0.55	60
8	8.00	0.60	85
10	8.00	0.68	115
12	8.00	0.75	155
14	8.00	0.66	195
16	8.00	0.70	240
18	8.00	0.75	280
20	8.00	0.80	340
24	8.00	0.89	455
30	10.00	1.03	760
36	10.00	1.15	1070
42	12.00	1.28	1505
48	12.00	1.42	1885

MJ SLEEVES

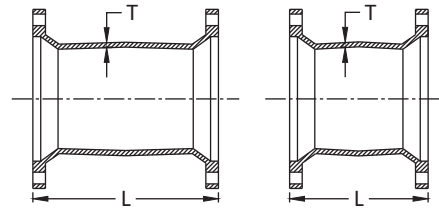

MJ SLEEVES		LONG		SHORT	
SIZE	T	L	WT	L	WT
*2	0.39	12.00	18	7.50	12
3	0.48	12.00	30	7.50	25
4	0.52	12.00	45	7.50	35
6	0.55	12.00	65	7.50	45
8	0.60	12.00	85	7.50	65
10	0.68	12.00	115	7.50	85
12	0.75	12.00	145	7.50	110
14	0.66	15.00	195	9.50	150
16	0.70	15.00	235	9.50	180
18	0.75	15.00	285	9.50	215
20	0.80	15.00	325	9.50	240
24	0.89	15.00	425	9.50	320
30	1.03	24.00	885	15.00	635
36	1.15	24.00	1190	15.00	855
42	1.28	24.00	1550	15.00	1115
48	1.42	24.00	1940	15.00	1385

TEES : MJ X MJ TANGENTIAL*

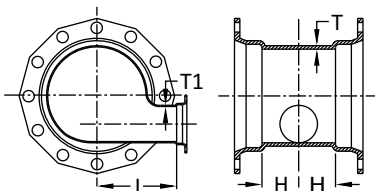

SIZE	T	T1	J	H	WT
20 x 4	0.80	0.52	17.00	14.00	826
20 x 8	0.80	0.60	17.00	14.00	851
24 x 4	0.89	0.52	19.00	15.00	1127
24 x 8	0.89	0.60	19.00	15.00	1153

* not included in AWWA C110

All dimensions are in inches unless noted otherwise.

All weights are approximate in pounds unless noted otherwise.

MJ LATERALS*

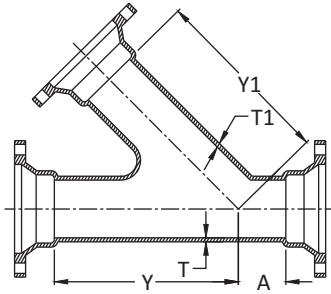

SIZE	T	T1	A	Y	Y1	WT
3 X 3	0.48	0.48	3.00	10.00	10.00	61
4 X 3	0.52	0.48	3.00	12.00	12.00	87
4 X 4	0.52	0.52	3.00	12.00	12.00	94
6 X 3	0.55	0.48	3.50	14.50	14.50	128
6 X 4	0.55	0.52	3.50	14.50	14.50	134
6 X 6	0.55	0.55	3.50	14.50	14.50	148
8 X 4	0.60	0.52	4.50	17.50	17.50	192
8 X 6	0.60	0.55	4.50	17.50	17.50	209
8 X 8	0.60	0.60	4.50	17.50	17.50	229
10 X 4	0.68	0.52	5.00	20.50	20.50	275
10 X 6	0.68	0.55	5.00	20.50	20.50	289
10 X 8	0.68	0.60	5.00	20.50	20.50	312
10 X 10	0.68	0.68	5.00	20.50	20.50	362
12 X 4	0.75	0.52	5.50	24.50	24.50	383
12 X 6	0.75	0.55	5.50	24.50	24.50	395
12 X 8	0.75	0.60	5.50	24.50	24.50	422
12 X 10	0.75	0.68	5.50	24.50	24.50	498
12 X 12	0.75	0.75	5.50	24.50	24.50	528
14 X 4	0.66	0.52	6.00	27.00	27.00	541
14 X 6	0.66	0.55	6.00	27.00	27.00	569
14 X 8	0.66	0.60	6.00	27.00	27.00	602
14 X 10	0.66	0.68	6.00	27.00	27.00	633
14 X 12	0.66	0.75	6.00	27.00	27.00	695
14 X 14	0.66	0.66	6.00	27.00	27.00	687
16 X 4	0.70	0.52	6.50	30.00	30.00	638
16 X 6	0.70	0.55	6.50	30.00	30.00	750
16 X 8	0.70	0.60	6.50	30.00	30.00	789
16 X 10	0.70	0.68	6.50	30.00	30.00	823
16 X 12	0.70	0.75	6.50	30.00	30.00	850
16 X 14	0.70	0.66	6.50	30.00	30.00	832
16 X 16	0.70	0.70	6.50	30.00	30.00	857
18 X 4	0.75	0.52	1.00	25.00	27.50	905
18 X 6	0.75	0.55	1.00	25.00	27.50	956
18 X 8	0.75	0.60	1.00	25.00	27.50	1005
18 X 10	0.75	0.68	7.00	32.00	32.00	1035
18 X 12	0.75	0.75	7.00	32.00	32.00	1092
18 X 14	0.75	0.66	7.00	32.00	32.00	1108

SIZE	T	T1	A	Y	Y1	WT
18 X 16	0.75	0.70	7.00	32.00	32.00	1147
18 X 18	0.75	0.75	7.00	32.00	32.00	1189
20 X 4	0.80	0.52	0.00	27.00	29.50	1235
20 X 6	0.80	0.55	0.00	27.00	29.50	1298
20 X 8	0.80	0.60	0.00	27.00	29.50	1355
20 X 10	0.80	0.68	1.00	27.00	29.50	1430
20 X 12	0.80	0.75	8.00	35.00	35.00	1295
20 X 14	0.80	0.66	8.00	35.00	35.00	1315
20 X 16	0.80	0.70	8.00	35.00	35.00	1380
20 X 18	0.80	0.75	8.00	35.00	35.00	1560
20 X 20	0.80	0.80	8.00	35.00	35.00	1827
24 X 6	0.89	0.55	0.50	31.50	31.50	975
24 X 8	0.89	0.60	0.00	31.50	34.50	1631
24 X 10	0.89	0.68	0.50	31.50	34.50	1670
24 X 12	0.89	0.75	0.50	31.50	34.50	1800
24 X 14	0.89	0.66	9.00	40.50	40.50	1771
24 X 16	0.89	0.70	9.00	40.50	40.50	1828
24 X 18	0.89	0.75	9.00	40.50	40.50	1890
24 X 20	0.89	0.80	9.00	40.50	40.50	1959
24 X 24	0.89	0.89	9.00	40.50	40.50	2132
30 X 8	1.03	0.60	10.00	49.00	49.00	---
30 X 12	1.03	0.75	10.00	49.00	49.00	2860
30 X 14	1.03	0.66	10.00	49.00	49.00	2935
30 X 16	1.03	0.70	10.00	49.00	49.00	2979
30 X 18	1.03	0.75	10.00	49.00	49.00	3062
30 X 20	1.03	0.80	10.00	49.00	49.00	3128
30 X 24	1.03	0.89	10.00	49.00	49.00	3287
30 X 30	1.03	1.03	18.25	52.50	52.50	3681
36 X 12	1.15	0.75	15.25	54.00	54.00	4912
36 X 14	1.15	0.66	15.25	54.00	54.00	4988
36 X 30	1.15	1.03	15.25	56.00	56.00	5823
36 X 36	1.15	1.15	19.50	60.00	60.00	6348
42 X 12	1.78	0.75	0.00	52.00	52.00	---
42 X 20	1.28	0.80	12.00	60.00	60.00	---
42 X 24	1.28	0.89	12.00	60.00	60.00	---
42 X 30	1.28	1.03	12.00	63.00	63.00	---
42 X 36	1.28	1.15	12.00	66.00	66.00	---
42 X 42	1.28	1.28	15.00	71.00	71.00	---
48 X 6	1.42	0.55	0.00	52.00	66.00	---
48 X 8	1.42	0.60	0.00	52.00	60.00	---
48 X 12	1.42	0.75	0.00	52.00	66.00	---
48 X 16	1.42	0.70	0.00	52.00	62.00	---
48 X 20	1.42	0.80	0.00	52.00	62.00	---
48 X 24	1.42	0.89	5.00	58.00	64.00	---
48 X 30	1.42	1.03	4.00	59.00	64.00	---
48 X 36	1.42	1.15	5.00	64.00	68.00	---
48 X 42	1.42	1.28	12.00	77.00	77.00	---
48 X 48	1.42	1.42	16.00	77.00	77.00	---

MJ X MJ TAPPED TEES & CROSSES

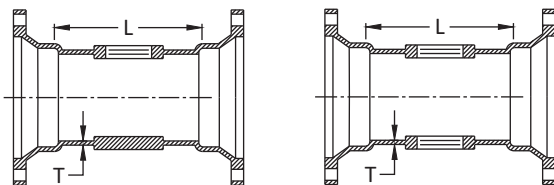

SIZE	T	L	TAP SIZE	WT
4 x 4	0.52	8.00	2.5	45
6 x 6	0.55	8.00	2.5	70
8 x 8	0.60	8.00	2.5	95
10 x 10	0.68	8.00	2.5	130
12 x 12	0.75	8.00	2.5	165
*16 x 16	0.70	8.00	2.5	270
*20 x 20	0.80	8.00	2.5	382
*24 x 24	0.89	9.00	2.5	519

All dimensions are in inches unless noted otherwise.

All weights are approximate in pounds unless noted otherwise.

* not included in AWWA C110

REDUCERS : MJ X MJ, PE X SMALL END MJ, LARGE END MJ X PE, MJ X FE, FE x MJ, MJ ECENTRIC

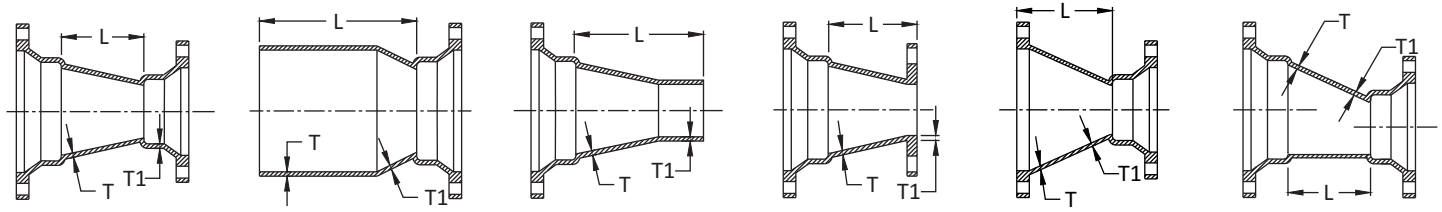

REDUCERS			MJ X MJ		PE X MJ SEB		MJ LEB X PE		MJ X FLANGE*		FLANGE X MJ*		MJ ECENTRIC*	
SIZE	T	T1	L	WT	L	WT	L	WT	L	WT	L	WT	L	WT
*3 X 2	0.48	0.39	6.00	25	14.00	14	14.00	20	6.00	21	---	---	---	---
*4 X 2	0.52	0.39	7.00	30	15.00	18	15.00	30	7.00	27	---	---	---	---
4 X 3	0.52	0.48	7.00	40	15.00	35	15.00	40	7.00	36	7.00	35	---	---
*6 X 2	0.55	0.39	9.00	45	17.00	45	17.00	45	9.00	43	---	---	---	---
6 X 3	0.55	0.48	9.00	55	17.00	50	17.00	55	9.00	51	---	---	---	---
6 X 4	0.55	0.52	9.00	60	17.00	60	17.00	60	9.00	57	9.00	63	9.00	69
*8 X 3	0.60	0.48	11.00	75	19.00	70	19.00	70	---	---	---	---	---	---
8 X 4	0.60	0.52	11.00	80	19.00	80	19.00	80	11.00	78	11.00	82	---	---
8 X 6	0.60	0.55	11.00	95	19.00	90	19.00	90	11.00	82	11.00	90	11.00	103
10 X 4	0.68	0.52	12.00	105	20.00	100	20.00	100	---	---	---	---	---	---
10 X 6	0.68	0.55	12.00	115	20.00	115	20.00	115	12.00	109	12.00	117	---	---
10 X 8	0.68	0.60	12.00	135	20.00	130	20.00	130	12.00	134	12.00	132	12.00	148
12 X 4	0.75	0.52	14.00	135	22.00	130	22.00	130	---	---	---	---	---	---
12 X 6	0.75	0.55	14.00	150	22.00	150	22.00	145	14.00	146	14.00	155	---	---
12 X 8	0.75	0.60	14.00	165	22.00	165	22.00	165	14.00	178	14.00	189	---	---
12 X 10	0.75	0.68	14.00	190	22.00	190	22.00	185	14.00	186	14.00	194	14.00	203
14 X 6	0.66	0.55	16.00	190	24.00	175	24.00	185	16.00	198	---	---	---	---
14 X 8	0.66	0.60	16.00	210	24.00	190	24.00	205	16.00	217	---	---	---	---
14 X 10	0.66	0.68	16.00	230	24.00	215	24.00	230	---	---	---	---	---	---
14 X 12	0.66	0.75	16.00	255	24.00	240	24.00	255	16.00	272	---	---	---	---
16 X 6	0.70	0.55	18.00	230	26.00	210	26.00	230	---	---	---	---	---	---
16 X 8	0.70	0.60	18.00	250	26.00	230	26.00	250	---	---	---	---	---	---
16 X 10	0.70	0.68	18.00	280	26.00	255	26.00	275	---	---	---	---	---	---
16 X 12	0.70	0.75	18.00	305	26.00	285	26.00	305	18.00	327	18.00	305	---	---
16 X 14	0.70	0.66	18.00	335	26.00	310	26.00	315	---	---	---	---	---	---
18 X 8	0.75	0.60	19.00	295	27.00	270	27.00	295	19.00	301	---	---	---	---
18 X 10	0.75	0.68	19.00	325	27.00	300	27.00	320	19.00	342	---	---	---	---
18 X 12	0.75	0.75	19.00	350	27.00	325	27.00	350	19.00	363	---	---	---	---
18 X 14	0.75	0.66	19.00	380	27.00	355	27.00	365	---	---	---	---	---	---
18 X 16	0.75	0.70	19.00	415	27.00	390	27.00	395	19.00	405	---	---	---	---
*20 X 8	0.80	0.60	20.00	345	28.00	345	---	---	---	---	---	---	---	---
20 X 10	0.80	0.68	20.00	375	28.00	345	28.00	375	---	---	---	---	---	---
20 X 12	0.80	0.75	20.00	405	28.00	375	28.00	405	---	---	---	---	---	---
20 X 14	0.80	0.66	20.00	430	28.00	400	28.00	415	---	---	---	---	---	---
20 X 16	0.80	0.70	20.00	470	28.00	435	28.00	445	20.00	512	---	---	---	---
20 X 18	0.80	0.75	20.00	510	32.00	475	28.00	485	---	---	---	---	---	---
24 X 12	0.89	0.75	24.00	550	32.00	510	32.00	550	24.00	459	---	---	---	---
24 X 16	0.89	0.70	24.00	615	32.00	575	32.00	595	---	---	---	---	---	---
24 X 18	0.89	0.75	24.00	660	32.00	620	32.00	635	---	---	---	---	---	---
24 X 20	0.89	0.80	24.00	705	38.00	665	32.00	675	---	---	---	---	24.00	721
*30 X 12	1.03	0.75	30.00	920	---	---	---	---	---	---	---	---	---	---
*30 X 16	1.03	0.70	30.00	945	38.00	830	---	---	---	---	---	---	---	---
30 X 18	1.03	0.75	30.00	990	38.00	885	38.00	965	---	---	---	---	---	---
30 X 20	1.03	0.80	30.00	1050	28.00	945	38.00	1020	---	---	---	---	---	---
30 X 24	1.03	0.89	30.00	1165	38.00	1060	38.00	1125	---	---	---	---	30.00	1178
36 X 20	1.15	0.80	36.00	1450	44.00	1285	44.00	1420	---	---	---	---	---	---
36 X 24	1.15	0.89	36.00	1580	44.00	1410	44.00	1535	---	---	---	---	---	---
36 X 30	1.15	1.03	36.00	1855	44.00	1690	44.00	1750	---	---	---	---	---	---
42 X 20	1.28	0.80	42.00	1915	50.00	1705	50.00	1880	---	---	---	---	---	---

* not included in AWWA C110

Con't

All dimensions are in inches unless noted otherwise.

All weights are approximate in pounds unless noted otherwise.

REDUCERS : MJ X MJ, PE X SMALL END MJ, LARGE END MJ X PE, MJ X FE, FE x MJ, MJ ECENTRIC (Con't)

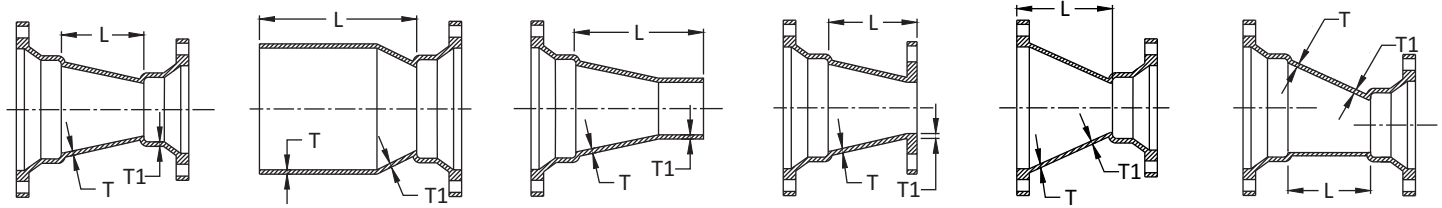

REDUCERS			MJ X MJ		PE X MJ SEB		MJ LEB X PE		MJ X FLANGE*		FLANGE X MJ*		MJ ECENTRIC*	
SIZE	T	T1	L	WT	L	WT	L	WT	L	WT	L	WT	L	WT
42 X 24	1.28	0.89	42.00	2060	50.00	1855	50.00	2020	---	---	---	---	---	---
42 X 30	1.28	1.03	42.00	2370	50.00	2165	50.00	2265	---	---	---	---	---	---
42 X 36	1.28	1.15	42.00	2695	50.00	2485	50.00	2530	---	---	---	---	---	---
48 X 30	1.42	1.03	48.00	3005	56.00	2740	56.00	2900	---	---	---	---	---	---
48 X 36	1.42	1.15	48.00	3370	56.00	3100	56.00	3205	---	---	---	---	---	---
48 X 42	1.42	1.28	48.00	3750	56.00	3480	56.00	3540	---	---	---	---	---	---

MJ OFFSETS

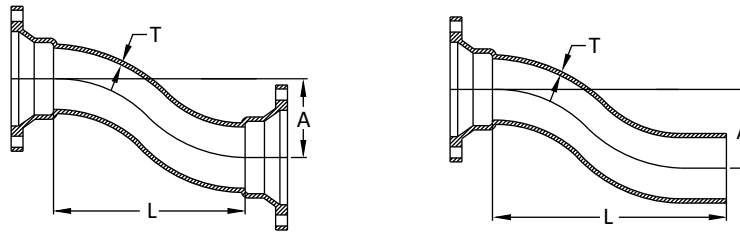

OFFSETS			MJ X MJ		MJ X PE	
SIZE	T	A	L	WT	L	WT
3 X 5	0.48	5.00	19.00	50	27.00	50
3 X12	0.48	12.00	22.00	60	30.00	60
3 X18	0.48	18.00	30.00	75	38.00	75
4 X 6	0.52	6.00	19.00	75	27.00	70
4 X12	0.52	12.00	22.00	85	30.00	80
4 X18	0.52	18.00	30.00	105	38.00	100
*4 X24	0.52	24.00	30.00	128	38.00	117
6 X 6	0.55	6.00	20.00	110	28.00	105
6 X12	0.55	12.00	26.00	135	34.00	130
6 X18	0.55	18.00	33.00	165	41.00	160
*6 X24	0.55	24.00	33.00	201	41.00	200
8 X 6	0.60	6.00	21.00	160	29.00	155
8 X12	0.60	12.00	28.00	200	36.00	195
8 X18	0.60	18.00	35.00	245	43.00	240
*8 X24	0.60	24.00	36.00	285	44.00	278
10X 6	0.68	6.00	22.00	220	30.00	220

OFFSETS			MJ X MJ		MJ X PE	
SIZE	T	A	L	WT	L	WT
10X12	0.68	12.00	30.00	250	38.00	280
10X18	0.68	18.00	38.00	340	46.00	340
*10X24	0.68	24.00	38.00	423	46.00	421
12X 6	0.75	6.00	26.00	320	34.00	320
12X12	0.75	12.00	37.00	420	45.00	420
12X18	0.75	18.00	48.00	520	56.00	520
*12X24	0.75	24.00	48.00	645	56.00	633
14X 6	0.66	6.00	27.00	380	35.00	365
14X12	0.66	12.00	38.00	480	46.00	465
14X18	0.66	18.00	49.00	585	57.00	570
16X 6	0.70	6.00	27.00	460	35.00	440
16X12	0.70	12.00	40.00	600	48.00	580
16X18	0.70	18.00	50.00	710	58.00	690
*20X12	0.80	12.00	40.00	1027	48.00	1018
*20X18	0.80	18.00	48.00	1276	60.00	1269

**SWIVEL X SWIVEL HYDRANT ELL*
WITH TWO-SWIVEL GLANDS**

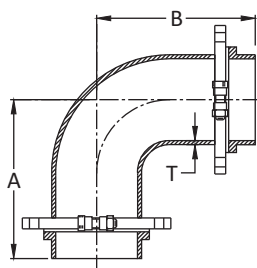

SIZE	T	A	B	WT
6	0.55	10.50	15.50	103
8	0.66	11.50	16.50	142

All dimensions are in inches unless noted otherwise.

All weights are approximate in pounds unless noted otherwise.

* not included in AWWA C110

SWIVEL X SOLID HYDRANT ADAPTER* (WITH SWIVEL GLAND)

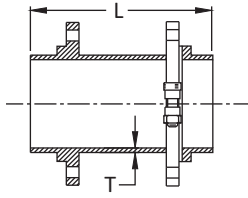

SIZE	L	T	WT
4 X 13	13.00	0.52	30
6 X 13	13.00	0.55	57
6 X 18	18.00	0.55	69
6 X 24	24.00	0.55	83
6 X 36	36.00	0.55	112
6 X 48	48.00	0.55	141
8 X 13	13.00	0.60	70
8 X 18	18.00	0.60	91
8 X 24	24.00	0.60	115
8 X 48	48.00	0.60	209
12X 13	13.00	0.75	127

SWIVEL GLAND*

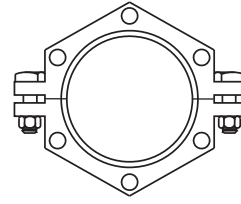

SIZE	WT
4	9
6	14
8	12
12	25

2 Nos. T-Head Bolts Required

For 4 to 8 Size - 3/4" X 3 1/2"
For 12 Size - 3/4" x 4"

SOLID AND TAPPED CAPS & PLUGS

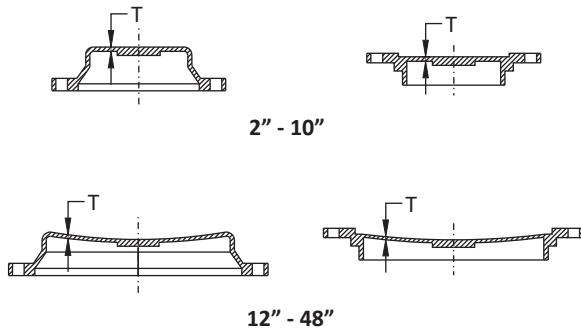

SIZE	T	MAX TAP	CAPS WT	PLUGS WT
*2	0.39	1 1/2	6	5
3	0.50	2	12	10
4	0.60	3	15	15
6	0.65	4	25	25
8	0.70	4	45	45
10	0.75	4	60	65
12	0.75	4	80	85
14	0.82	5	120	115
16	0.89	6	155	145
18	0.96	6	195	185
20	1.03	6	240	225
24	1.16	6	345	335
30	1.03	6	590	573
36	1.15	6	850	815
42	1.28	6	1180	1110
48	1.42	6	1595	1455

MJ FULL BODY GLANDS*

SIZE	O.D.	A	B	C	I.D.	B.C.	BOLT HOLE	BOLT QTY.	WT
2	6.12	0.62	1.37	3.40	2.61	4.75	Ø0.75	2	1
3	7.69	0.62	1.50	4.84	4.06	6.19	Ø0.75	4	5
4	9.12	0.75	1.63	5.92	4.90	7.50	Ø0.88	4	6
6	11.12	0.88	1.75	8.02	7.00	9.50	Ø0.88	6	10
8	13.37	1.00	1.75	10.17	9.15	11.75	Ø0.88	6	14
10	15.62	1.00	1.75	12.22	11.20	14.00	Ø0.88	8	20
12	17.88	1.00	2.00	14.32	13.30	16.25	Ø0.88	8	24
14	20.25	1.25	2.06	16.40	15.44	18.75	Ø0.88	10	45
16	22.50	1.31	2.13	18.50	17.54	21.00	Ø0.88	12	55
18	24.75	1.38	2.19	20.60	19.64	23.25	Ø0.88	12	55
20	27.00	1.44	2.31	22.70	21.74	25.50	Ø0.88	14	66
24	31.50	1.56	2.75	26.90	25.94	30.00	Ø0.88	16	90
30	39.12	2.00	2.75	33.29	32.17	36.88	Ø1.13	20	220
36	46.00	2.00	2.75	39.59	38.47	43.75	Ø1.13	24	286
42	53.12	2.00	2.75	45.79	44.67	50.62	Ø1.38	28	288
48	60.00	2.00	1.12	52.09	50.97	57.50	Ø1.38	32	400

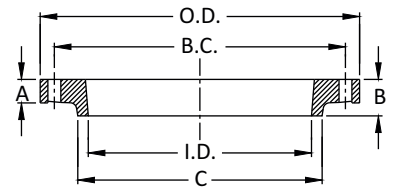

* not included in AWWA C110

All dimensions are in inches unless noted otherwise.

All weights are approximate in pounds unless noted otherwise.



SIP Industries

Quality Manufacturers Since 1960



PRODUCT LINE

AWWA DI Fittings & Accessories

- C153 Compact MJ Fittings and Acc. 2" - 64"
- C110 Full Body MJ Fittings 2" - 64"
- C153 Trim Tyton® Push-On Fittings 4" - 24"
- C110 Flange Fittings 2" - 64"
- MJ x MJ Adapter for Connecting MJ Bells 3" - 24"
- Stainless Steel & Blue T-Bolts
- Made in India, China & Mexico
- Bare, Cement, Zinc, FBE & Other Linings

Joint Restraint System

- EZD Joint Restraint for DI Pipe 3" - 48"
- EZDTP Joint Restraint Tandem for DI Pipe 3" - 48"
- EZDPTP Joint Restraint for Push-On Joints DI Pipe 3" - 48"
- Ductile Iron Retainer Glands 3" - 30"
- FAR / FAH Flange Adapter for DI Pipe 3" - 48"
- EZFA Restrained Flange Adapter for DI and PVC Pipe 3" - 36"
- EZPVC Joint Restraint for PVC Pipe 3" - 36"
- ULTRA Joint Restraint for PVC Pipe 4" - 12"
- EZPVCPTP Joint Restraint for Push-On Joints PVC Pipe 14" - 36"
- PTPVC Pipe to Pipe Restraint 4" - 48"
- PTPDF Pipe to MJ Fittings Restraint 4" - 48"
- PTPFC Pipe to PVC Fittings Restraint 4" - 12"
- Made in China & USA
- EZ Shield or Shop Coating

Municipal Construction Castings

- Manhole Rings and Cover
- Frames and Grates
- Valve Boxes and Service Boxes
- Water Meter Covers and Boxes
- Cleanout and Monument Boxes
- Detectable Warning Plates
- Extension Rings
- Trench Grates and Tree Grates
- Made in India & USA

Fabrication Products for DI Pipe

- High Hub Flanges Class 150 and 250. 3" - 64"
- Threaded Bell Flanges 3" - 48"
- Anchor Flanges 3" - 60"
- Filler Flanges 4" - 30"

Other Products and Services

- All Thread Rod
- Pipe Lube and Hydraulic Cement
- Socket Clamps and Lugs
- Flange Packs
- OEM Castings



SIP CORPORATE 8876 Gulf Freeway, Suite 500, Houston, TX 77017

SIP CENTRAL 2900 Patio Drive, Houston, TX 77017

SIP EAST 600 Rayloc Drive, Atlanta, GA 30336

SIP WEST 8333 Almeria Avenue, Fontana, CA 92335

Phone: 877-921-6111 or 713-923-6111 | Fax: 713-923-6114 | www.sipindustries.com | sales@sipindustries.com