



4" - 12" MECHANICAL JOINT RESTRAINT FOR PVC PIPE - 'ULTRA'

Submittal Information

Project Name / Location:	
Engineer:	
Referenced Specs:	
Distributor / Contractor:	

Optional Specifications

Coating:	Standard Alkyd, Direct To Metal (DTM) Enamel (Red)
	EZ-Shield® Polyester Based Powder Coating (Red)
	Other - Specify:
Bolts / Nuts:	Standard High Strength Low Alloy Steel (HSLA) <i>In Accordance With ANSI/AWWA C111/A21.11</i>
	Fluoropolymer Corrosion Resistant Coating
	Stainless Steel: Type 304 Type 316
Gaskets:	Other - Specify:
	Standard SBR (Buna-S) <i>In Accordance With ANSI/AWWA C111/A21.11</i>

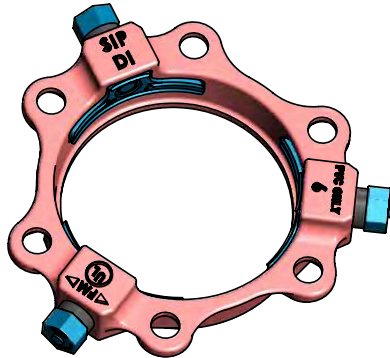

General Specifications

- Material** : Gland, wedges, twist-off nuts and actuating screws are Ductile Iron per ASTM A536, Grade 65-45-12
- Pressure** : Pressure rating equal to that of the PVC pipe rating, with a minimum 2:1 safety factor.
The contoured grip of the wedges increases as the hydrostatic pressure increases
- Dimensions** : Gland complies with all applicable dimensions of, and is compatible with, all mechanical joint sockets of ANSI/AWWA C111/A21.11, C110/A21.10, and C153/A21.53 Standards.
Compatible with 4" - 12" AWWA C900 (PVC), C906 (HDPE)*, C909 (PVCO) or 4"-12" ASTM D2241 IPS PVC Pipe
*** AWWA C906 HDPE Pressure Pipes up to 12" by using internal pipe stiffeners.**
*** IPS PVC Pipe applications require use of a Transition Gasket.**
- Installations** : Install in accordance with SIP installation procedures and intent of AWWA C600 / C605 / M23 / M41.
Pipe ends must be free from defects to allow wedges to properly engage the pipe ends.
Wedge pockets must be free from debris intrusion to allow movement, polyethylene wrap of the restraint is recommended as a prevention.
Note: No additional tool required for installation other than the tool required to install a standard Mechanical Joint T-Bolt and 1-1/4" Nut. The hex head of the actuating screw is designed to break off at a preset torque. After the removal of the 1-1/4" torque control hex head, a 5/8" hex head on the actuating screw remains in order to allow, if necessary, for the disassembly and re-installation of the gland and restraint mechanism
- Deflection** : 5° on sizes 4" - 12"
- Coating** : Wedges, twist-off nuts and actuating screws fluoropolymer coated
- Approvals** : UL Listed for sizes 4"-12" at 235psi on AWWA C900 Class 235 DR-18 PVC pipe. FM Approved for sizes 4"-12" at 250psi on AWWA C900 Class 305 DR-14 PVC pipe and at 200psi on AWWA C900 Class 235 DR-18 PVC pipe.
Tested and found In accordance with ASTM F1674 Standard for PVC *
*** These PSI Ratings are the Highest Ratings for this type of Restraint in the Industry**



Supporting documentation for the above 'General Specifications' and 'Optional Specifications' are available upon request to review, in addition to Installation Instructions and any requested material samples

Please contact SIP for technical assistance of nonstandard applications and pressures

Please refer to our web page www.sipindustries.com for up to date product data and technical advisories

4" - 12" MECHANICAL JOINT RESTRAINT FOR PVC PIPE - 'ULTRA'

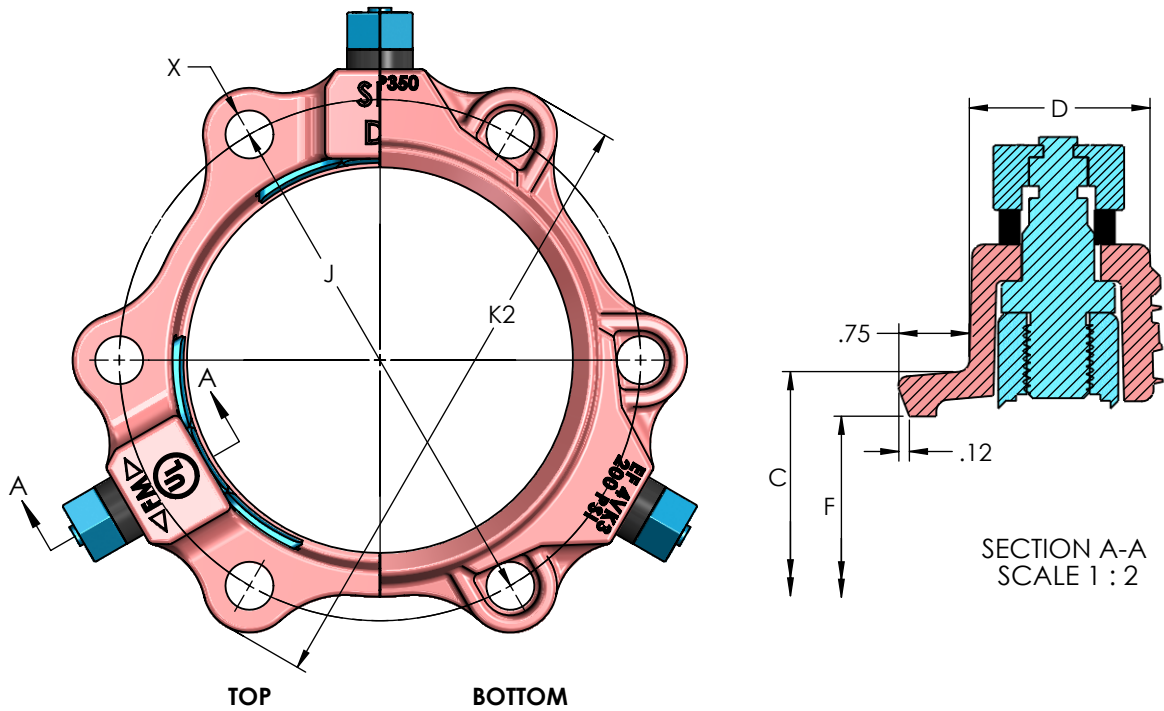

Technical Specifications

Select Size	Size	Series Number	C	D	F	X	J	K2	Bolt Qty	Wedge Qty	Approx. Weight (LBS)
	4	EZPVCU04	5.92	1.83	4.90	7/8	7.50	9.16	4	2	7.22
	6	EZPVCU06	8.02	1.87	7.00	7/8	9.50	11.12	6	3	10.74
	8	EZPVCU08	10.17	1.88	9.15	7/8	11.75	13.75	6	4	15.13
	10	EZPVCU10	12.22	2.03	11.20	7/8	14.00	15.91	8	6	22.37
	12	EZPVCU12	14.32	2.05	13.30	7/8	16.25	18.23	8	6	25.50

All dimensions are in inches unless noted otherwise. All weights are approximate in pounds unless noted otherwise.

STANDARDIZED PRESSURE RATINGS							
ANSI/AWWA C900 CI OD		ANSI/AWWA C905 CI OD		C909 PVC0 Pressure Pipe		ASTM D2241 IPS OD	
DR 14	305 PSI	DR 18	235 PSI	PC235	235	SDR 17	250 PSI
DR 18	235 PSI	DR 21	200 PSI			SDR 21	200 PSI
DR 25	165 PSI	DR 25	165 PSI			SDR 26	160 PSI
		DR 32.5	125 PSI				