



3" - 48" MECHANICAL JOINT RESTRAINT FOR DUCTILE IRON PIPE

Submittal Information

Project Name / Location:	
Engineer:	
Referenced Specs:	
Distributor / Contractor:	

Optional Specifications

Coating:	Standard Alkyd, Direct To Metal (DTM) Enamel (Black)		
	EZ-Shield® Polyester Based Powder Coating (Black)		
	Other - Specify:		
Bolts / Nuts:	Standard High Strength Low Alloy Steel (HSLA) In Accordance With ANSI/AWWA C111/A21.11		
	Fluoropolymer Corrosion Resistant Coating		
	Stainless Steel:	Type 304	Type 316
Gaskets:	Standard SBR (Buna-S) In Accordance With ANSI/AWWA C111/A21.11		
	Other - Specify:		



General Specifications

- Material** : Gland, Heat Treated wedges, twist-off nuts and actuating screws are Ductile Iron per ASTM A536
- Pressure** : Grade 65-45-12 350 PSI rating for 4"- 16" sizes, 250 PSI for sizes 18" and larger
- Dimensions** : Gland complies with all applicable dimensions of, and is compatible with, all mechanical joint sockets of ANSI/AWWA C111/A21.11, C110/A21.10, and C153/A21.53 Standards.
- Installation** : Install in accordance with SIP installation procedures and intent of AWWA C600 / M41.
Pipe ends must be free from defects to allow wedges to properly engage the pipe ends.
Wedge pockets must be free from debris intrusion to allow movement, polyethylene wrap of the restraint is recommended as a prevention.
Per ANSI/AWWA C600 and C111 using DIP conforming to C150/C151, and Steel Pipe 3"-12"
*Steel Pipe applications require use of a Transition Gasket.
*Sizes 42" and larger require longer T-Bolts for proper installation.
* **Not for use on Spigot End of M.J. x P.E. Fittings or on P.E. x P.E. Fittings.**
Note: No additional tool required for installation other than the tool required to install a standard Mechanical Joint T-Bolt and 1-1/4" Nut. The hex head of the actuating screw is designed to break off at a preset torque. After the removal of the 1-1/4" torque control hex head, a 5/8" hex head on the actuating screw remains in order to allow, if necessary, for the disassembly and re-installation of the gland and restraint mechanism
- Deflection** : 5° on sizes 3" - 12", 3° on 14"-24", 2° on 30"-36" and 1° on 42"- 48"
- Coating** : Wedges, twist-off nuts and actuating screws Fluoropolymer coated
- Approvals** : Sizes 3" - 24" UL Listed and sizes 3" - 12" FM Approved



Supporting documentation for the above 'General Specifications' and 'Optional Specifications' are available upon request to review, in addition to Installation Instructions and any requested material samples

Please contact SIP for technical assistance of nonstandard applications and pressures

Please refer to our web page www.sipindustries.com for up to date product data and technical advisories

3" - 48" MECHANICAL JOINT RESTRAINT FOR DUCTILE IRON PIPE

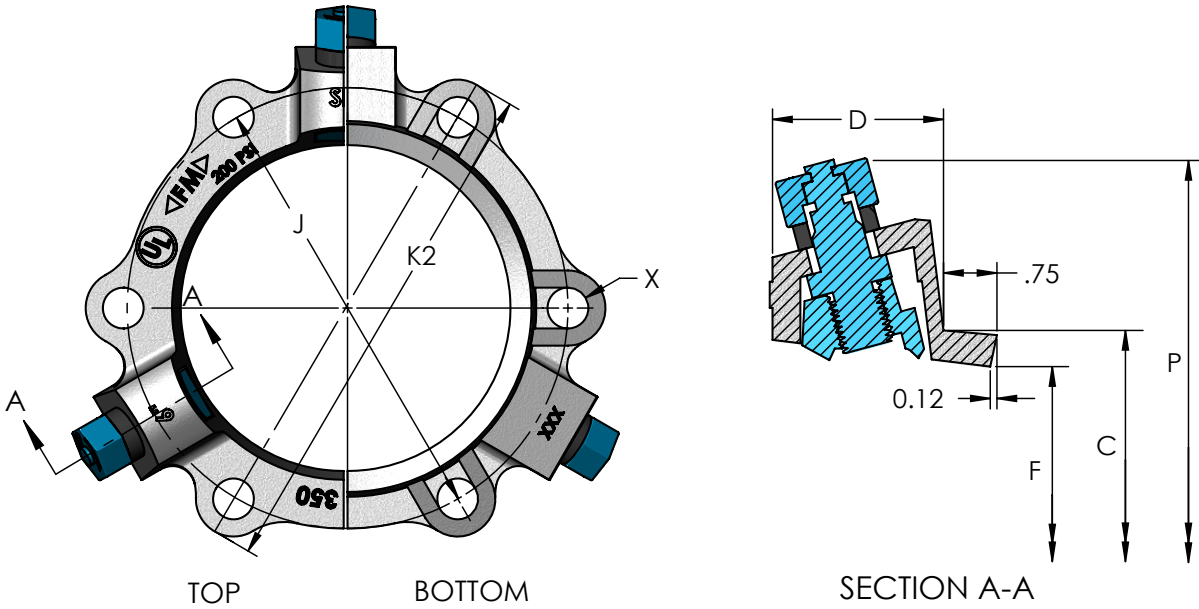

Technical Specifications

Select Size	Size	Series Number	C	D	F	J	X	P	K2	Bolt Qty	Wedge Qty	Approx. Weight (Lbs)
	3	EZD03	4.84	2.43	4.06	6.19	3/8	10.00	7.69	4	2	6.38
	4	EZD04	5.92	2.46	4.90	7.50	3/8	11.00	9.12	4	2	7.88
	6	EZD06	8.02	2.46	7.00	9.50	3/8	13.14	11.12	6	3	11.57
	8	EZD08	10.17	2.46	9.15	11.75	3/8	15.30	13.39	6	4	15.91
	10	EZD10	12.22	2.46	11.20	14.00	3/8	17.30	15.62	8	6	22.34
	12	EZD12	14.32	2.46	13.30	16.25	3/8	19.45	17.89	8	8	29.82
	14	EZD14	16.40	2.98	15.44	18.75	3/8	21.45	20.80	10	10	49.90
	16	EZD16	18.50	2.84	17.54	21.00	3/8	24.20	22.50	12	12	58.02
	18	EZD18	20.60	2.95	19.64	23.25	3/8	26.00	25.25	12	12	68.52
	20	EZD20	22.70	2.91	21.74	25.50	3/8	28.20	27.50	14	14	75.94
	24	EZD24	26.90	3.20	25.94	30.00	3/8	33.50	31.87	16	16	126.18
	30	EZD30	33.29	3.50	32.17	36.88	1 1/8	39.80	39.12	20	20	196.6
	36	EZD36	39.59	3.50	38.47	43.75	1 1/8	46.10	46.00	24	24	243.52
	42	EZD42	45.79	5.18	44.67	50.62	1 3/8	54.50	53.12	28	28	441.96
	48	EZD48	52.09	5.18	50.97	57.50	1 3/8	60.80	60.00	32	32	522.24

All dimensions are in inches unless noted otherwise. All weights are approximate in pounds unless noted otherwise.