



# SIP Industries

Quality Manufacturers Since 1960



## Compact Push-On Fittings

ANSI/AWWA C153/21.53

[www.sipindustries.com](http://www.sipindustries.com)

Toll Free 877-921-6111



★ ★ ★  
**SIP INDUSTRIES**  
SERAMPORE  
SINCE 1960



**TABLE OF CONTENTS**

General Terms & Conditions.....	Page : CPO02-CPO04
General & Technical Specifications.....	Page : CPO05
PO X PO Bends.....	Page : CPO06
PO X FLANGE Bends.....	Page : CPO06
PO X PE Bends.....	Page : CPO06
PO X PO Tees.....	Page : CPO07
PO X FLANGE Tees.....	Page : CPO07
PO X SWIVEL Hydrants Tees.....	Page : CPO07
PO Crocess.....	Page : CPO07
PO X PE Tees.....	Page : CPO08
PO X PO Reducers.....	Page : CPO08
PO X PE Reducers.....	Page : CPO08
PO LATERALS.....	Page : CPO08
PO FLANGE Adapters.....	Page : CPO09
PO Tapped Tees.....	Page : CPO09
PO Tapped Crosses.....	Page : CPO09
PE X Small End PO Reducers.....	Page : CPO09
PO Solid & Tapped Caps & Plugs.....	Page : CPO09
PO Gaskets.....	Page : CPO09
PO Transition Gaskets.....	Page : CPO09

- **All dimensions are in inches unless noted otherwise.**
- **All weights are approximate in pounds unless noted otherwise.**

**1. Acceptance.** All sales by SIP Industries (Seller) are made pursuant to these Terms and Conditions. Submission of a purchase order to Seller, and/or acceptance of goods delivered by Seller, shall be deemed an acceptance of these Terms and Conditions by Purchaser. Please note that these Terms and Conditions may be modified from time to time; the applicable Terms and Conditions are those posted on SIP's website, [www.sipindustries.com](http://www.sipindustries.com), at the time that a purchase order is accepted or an agreement otherwise confirmed. Purchaser's alteration or addition to these Terms and Conditions, as same may be in effect from time to time, is expressly rejected unless accepted in writing by an authorized representative of Seller.

**2. Entire Agreement.** These Terms and Conditions, together with Seller's price list and Purchaser's purchase order, when accepted by Seller, shall be the entire agreement between Seller and Purchaser. Neither Seller nor Purchaser is relying on any representations, warranties or agreements except as expressly provided in these Terms and Conditions and in an accepted purchase order. To the extent of any conflict between the terms of a purchase order or any other documents submitted by Purchaser, on the one hand, and these Terms and Conditions, on the other, these Terms and Conditions shall govern.

**3. Prices.** Prices and descriptions of goods stated in Seller's price lists are subject to change without notice. Prices are subject to tariffs, raw material surcharges, labor disputes and shipping surcharges. To submit a purchase order, SIP Industries item numbers and part codes should be included. Seller's quotations are on globally sourced products unless otherwise noted. The ordering party is responsible to specify any required origin as required for end use. Quotations, if provided by Seller, expire sixty (60) days from the date provided unless otherwise agreed in writing.

**4. Terms.** Invoices are due and payable thirty (30) days from date of shipment, unless otherwise written on the invoice or confirmed in writing by Seller. A five percent (5%) late fee will be charged on all past-due accounts. If it becomes necessary to retain attorneys to collect an account, the Purchaser is liable for Seller's attorney's fees and other costs of collection.

**5. FOB point of shipment.** All prices are FOB point of shipment, unless otherwise agreed in writing. Seller's responsibility for goods therefore ceases and title passes to the Purchaser at the point of shipment; all claims for damages or losses in transit must be directed to the carrier with copy to Seller within ten (10) days of shipment.

**6. Delivery.** Seller shall have the right to select the freight carrier unless otherwise agreed. Seller has the right to substitute material with same function and design to accommodate unforeseen delays, shortages or restrictions.

**7. Cancellations, Changes and Returns.** All cancellations, changes and returns must be accepted in writing by an authorized representative of Seller, otherwise they will not be valid and binding on Seller. Seller will not be responsible for unauthorized returned product. It will be the responsibility of purchaser at their expense to have unauthorized product returned or disposed of. Seller shall not be obligated to accept any cancellation, change or return, but if it does so the following terms shall apply: (i) goods must be returned to Seller's facility, in the same condition in which they were accepted by Purchaser; (ii) a handling charge of thirty-five percent (35%) of the purchase price will be deducted from the credit given to Purchaser; and (iii) shipping charges, if not prepaid by Purchaser, will likewise be deducted from the credit given to Purchaser.

**8. Specially Manufactured Goods.** Unless otherwise agreed, specially-manufactured goods, including goods designed to the Purchaser's specifications, may not be cancelled or returned once work has begun to design or manufacture the goods unless an agreement is reached and confirmed in writing by Seller, including compensation to Seller for work thus far done with respect to the goods.

**9. Delays; Force Majeure.** Seller shall not be liable for any expenses, loss or damage resulting from any delay in delivery of goods or other failure of Seller's performance due to fire, floods, acts of god, strikes, labor disputes, labor shortages, riots, accidents, transportation delays or other causes beyond the reasonable control of Seller.

**10. Disclaimer regarding weights.** All stated weights are approximate and are given for inventory and shipping purposes only.

**11. Taxes.** Seller's prices do not include sales, excise or other taxes. Purchaser shall pay all such taxes. If Purchaser claims a tax exemption, Purchaser shall provide Seller with the necessary tax-exemption numbers and certificates. If Purchaser aims a tax exemption, Purchaser shall provide Seller with the necessary tax-exemption numbers and certificates. If Seller accepts an exemption but is later required by the taxing authority to pay taxes, Purchaser shall reimburse to Seller the amount of such taxes.

**12. Limited Warranty.** For a period of one calendar year from the date of shipment, Seller warrants that goods sold and delivered by Seller to Purchaser will conform to the number and type of goods described in the accepted purchase order and that such goods will be free from defects in material and workmanship.

THIS LIMITED WARRANTY IS SELLER'S SOLE AND EXCLUSIVE WARRANTY. SELLER MAKES NO OTHER WARRANTY OF ANY KIND, EXPRESS OR IMPLIED. SELLER DOES NOT WARRANT THAT THE GOODS ARE FIT FOR ANY PARTICULAR PURPOSE. SELLER DOES NOT WARRANT THAT THE GOODS ARE MERCHANTABLE.

**13. Product Disclaimers.** All tooling required to manufacture products are the property of Seller even if tooling costs are incurred by Purchaser. Seller has the right to change product design, engineering, materials, tooling and processes that do not affect the intended use and application of the product. Seller will notify Purchaser if changes are substantial and may affect the application or appearance of the product. Furthermore, references to Buyer's specifications and similar requirements are only to describe the goods and do not give rise to any representation, warranty or other sales term.

Seller manufactures to industry standards and makes every effort to address applications of its products. Please see current technical advisory at Seller's web site, sipindustries.com, for up to date product support and recommendations. All product dimension, designs, technology, tooling, process, software, innovations, and drawings are considered intellectual property and are owned and confidential to Seller. Purchaser has no rights or privileges to SIP industries intellectual property including product applications without Seller's express written consent.

**14. Prompt notice required for Limited Warranty claims.** Buyer is responsible for promptly inspecting goods on delivery and notifying Seller, within sixty (60) days of delivery to Buyer, of any nonconformity or defect that would be discovered on a reasonable and customary inspection. Provided that such notice is given and that the warranty claim is made within one year, Seller will provide a replacement or price adjustment, in Seller's discretion, not to exceed the net sales price of the defective product. However, this warranty shall be of no force or effect absent such timely notice. Seller shall not in any event be responsible for labor, removal or installation charges incurred in connection with the replacement of defective goods.

**15. Conditions to Limited Warranty.** Purchaser shall notify Seller immediately upon discovery of a defect so that Seller may inspect the product in its installed condition. Seller shall not be responsible for defects or failures in goods of which it is not so notified; nor shall Seller be responsible for goods manufactured or sold by other parties or losses or impairments caused by such goods; nor shall Seller be responsible for defects or failure of goods due to improper installation, improper usage, normal or abnormal wear and tear, erosion or corrosion, improper storage, use or maintenance, vandalism, vehicular or other accidents, or storms or other forces beyond the control of the parties. Seller also shall not be responsible for goods that have been damaged by misuse, negligence or accident or that have been altered or repaired by any party other than Seller.

**16. Limitation on Liability.** In the event any remedy hereunder fails of its essential purpose and monetary damages may be imposed, Seller's liability, whether founded in contract or tort (including negligence), arising out of or resulting from (i) the Purchase Order and resulting contract or the performance or breach thereof, or (ii) the design, manufacture, delivery, sale, repair, replacement or use of the goods, shall not exceed the cost of the goods at issue in the claim. NOTWITHSTANDING ANYTHING CONTAINED HEREIN TO THE CONTRARY, SELLER SHALL NOT BE LIABLE TO PURCHASER OR ANY OTHER PERSON FOR CONSEQUENTIAL, INCIDENTAL, SPECIAL, EXEMPLARY, PUNITIVE OR OTHER INDIRECT DAMAGES, INCLUDING, WITHOUT LIMITATION, LOSS OF PROFITS, RECALL-RELATED EXPENSES, AND LOSS OF USE OF THE GOODS.

**17. Purchaser specifications.** If Seller has designed the goods using information provided by Purchaser, Seller shall not be responsible for design errors resulting from inaccurate or incomplete information supplied by Purchaser. If

Purchaser has provided specifications or a model or sample from which a good is designed and manufactured, Seller shall not be responsible for any defect, error or inadequacy provided that the good is designed or manufactured in compliance with Purchaser's specifications, model or sample.

**18. Solvency and Security Interest.** By submitting a Purchase Order, Buyer represents to Seller that Buyer is solvent and capable of timely fulfilling its payment and other obligations to Seller. Until the goods and any other indebtedness of Buyer have been paid in full, Buyer, its agents any successors: (i) will hold the goods subject to a security interest in favor of Seller allowing for the right or re-possession by Seller to the extent permitted by applicable law, (ii) will not alter, remove, destroy, or damage any identifying mark on the goods or their packaging, and (iii) will keep the goods separate from any other products.

**19. Governing law; venue.** All sales shall be governed by the law of the state of Texas. In the event that a lawsuit is filed between the parties on any claim arising out of or in connection with such sales, Seller and Purchaser agree that exclusive venue and jurisdiction shall be in the state or federal courts of Harris County, Texas.

**20. Attorney's fees and costs.** In the event of litigation between the parties with respect to the sale of goods, the prevailing party shall be entitled to recover its reasonable attorney's fees and costs, including expert witness fees.



**4" - 24" DUCTILE IRON PUSH-ON JOINT COMPACT FITTINGS**

**General Specifications**

- Material** : Ductile Iron per ASTM A536
- Pressure** : 350 PSI rating for 4"- 24"sizes  
Pressure rating applies to fittings only, does not apply to Restraining Lugs or External Restrainers
- Testing** : In accordance with ANSI/AWWA C153/A21.53 and UL, FM requirements
- Laying Length** : In accordance with ANSI/AWWA C153/A21.53  
(fittings not listed in ANSI/AWWA have dimensions per SIP design as noted in the catalog)
- Joint** : TRIM TYTON® push-on bell joint design, manufactured by SIP Industries, under license from US Pipe  
TRIM TYTON® is a registered trademark of United States Pipe and Foundry Company, LLC.  
Note: Push-On End Ears are for installation purposes
- Flanges** : Flanged ends on fittings match ANSI/AWWA C115/A21.15 and ANSI B16.1 class 125 flanges
- Gaskets** : Dual hardness SBR in accordance with ANSI/AWWA C111/A21.11 (see fittings accessories catalog)
- Cement Lining** : In accordance with ANSI/AWWA C104/A21.4 -- size 4" - 24" double thickness
- Coating** : Asphaltic seal coat inside and out in accordance with ANSI/AWWA C104/A21.4 and referenced in ANSI/AWWA C153/A21.53
- Weight** : Are in pounds, unless noted otherwise and do not include accessories, cement lining and coating
- Dimensions** : All dimensions are in inches unless noted otherwise.
- Installations** : Per ANSI/AWWA C600 and C111 using DIP conforming to C150/C151 and PVC pipe conforming to C900/C905
- Approvals** : 4" - 24" UL Listed | 4" - 24" FM Approved | 4" and higher UL/NSF Standards 61 | 4" and higher NSF/ANSI Standards 61 Approved for Drinking Water. Please consult SIP for detail listing and approvals.

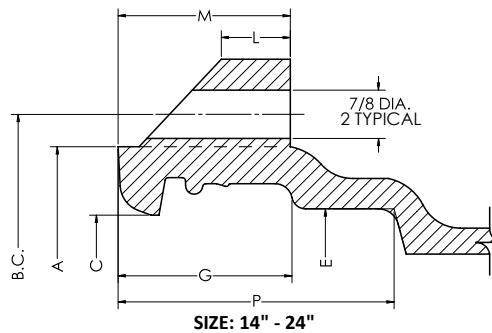
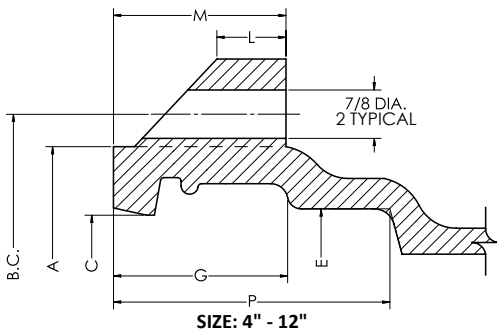

ANSI/NSF 61  
DRINKING WATER SYSTEM COMPONENTS

**Technical Specifications**

SIZE	C	E	A	B.C.	P	G	M	L
4	4.91	5.04	6.47	7.50	4.02	1.85	2.17	0.87
6	7.01	7.14	8.67	9.56	4.02	1.98	2.17	0.87
8	9.17	9.32	10.93	11.82	4.49	2.47	2.72	1.00
10	11.22	11.37	13.04	14.00	4.49	2.67	2.91	1.12
12	13.32	13.47	15.18	16.25	5.00	2.67	2.99	1.12
14	15.41	15.64	17.89	19.06	5.00	3.15	3.12	1.25
16	17.51	17.74	20.05	21.25	5.50	3.15	3.25	1.25
18	19.61	19.84	22.35	23.50	5.50	3.15	3.25	1.25
20	21.71	21.94	24.47	25.75	6.00	3.15	3.25	1.25
24	25.91	26.14	28.79	30.09	6.00	3.15	3.25	1.25

All dimensions are in inches unless noted otherwise.

All weights are approximate in pounds unless noted otherwise.

\* not included in AWWA C153

## PO X PO BENDS

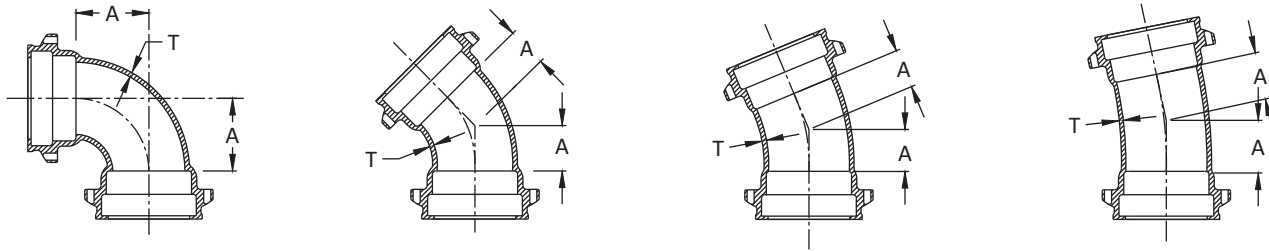

PO X PO		90° BENDS (¼)		45° BENDS (⅛)		22.5° BENDS (⅙)		11.25° BENDS (⅓₂)	
SIZE	T	A	WT	A	WT	A	WT	A	WT
4	0.34	4.00	26	2.00	23	1.50	22	1.25	21
6	0.36	5.00	41	3.00	38	2.00	34	1.50	32
8	0.38	6.50	71	3.50	54	2.50	55	1.75	52
10	0.40	7.50	98	4.50	87	3.00	75	2.00	67
12	0.42	9.00	139	5.50	110	3.50	105	2.25	95
14	0.47	11.50	254	5.00	143	3.75	162	2.50	113
16	0.50	12.50	275	5.50	206	3.75	168	2.50	172
18	0.54	14.00	400	6.00	309	4.50	209	3.00	209
20	0.57	15.00	480	7.00	397	4.50	400	3.00	265
24	0.61	16.75	704	7.50	414	7.50	410	3.00	315

## PO X FLANGE BENDS\*

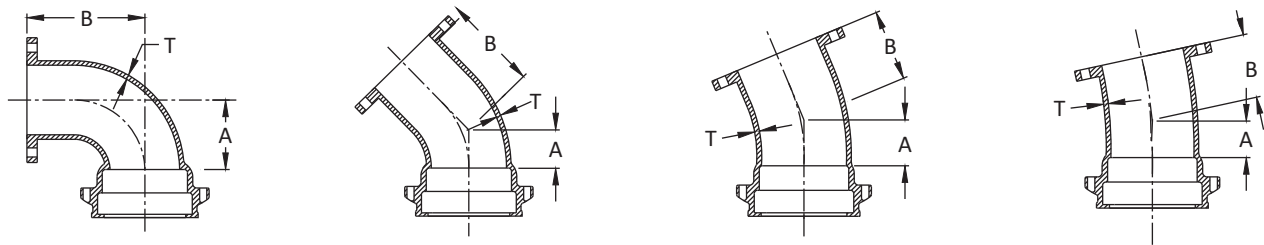

PO X FLANGE		90° BENDS (¼)			45° BENDS (⅛)			22.5° BENDS (⅙)			11.25° BENDS (⅓₂)		
SIZE	T	A	B	WT	A	B	WT	A	B	WT	A	B	WT
4	0.34	4.00	6.50	33	2.00	4.00	21	1.50	4.00	25	1.25	4.00	24
6	0.36	5.00	8.00	47	3.00	5.00	42	2.00	5.00	44	1.50	5.00	30
8	0.38	6.50	9.00	76	3.50	5.50	60	2.50	5.50	64	1.75	5.50	61
10	0.40	7.50	11.00	130	4.50	6.50	93	3.00	6.50	90	2.00	6.50	80
12	0.42	9.00	12.00	158	5.50	7.50	122	3.50	7.50	112	2.25	7.50	94
14	0.47	11.50	14.00	231	5.00	7.50	162	3.75	7.50	174	2.50	7.50	170
16	0.50	12.50	15.00	350	5.50	8.00	275	3.75	8.00	228	2.50	8.00	228
18	0.54	14.00	16.50	409	6.00	8.50	350	4.50	8.50	340	3.00	8.50	350
20	0.57	15.00	18.00	480	7.00	9.50	420	4.50	9.00	380	3.00	9.00	390
24	0.61	16.75	22.00	630	7.50	11.00	450	4.50	11.00	420	3.00	11.00	430

## PO X PE BENDS

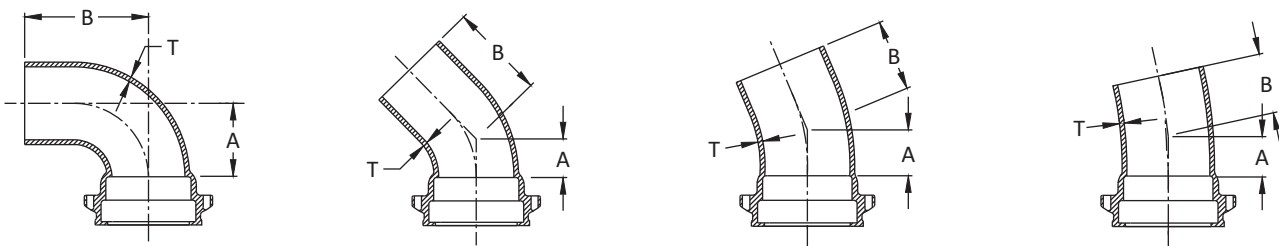

PO X PE		90° BENDS (¼)			45° BENDS (⅛)			22.5° BENDS (⅙)			11.25° BENDS (⅓₂)		
SIZE	T	A	B	WT	A	B	WT	A	B	WT	A	B	WT
4	0.34	4.00	10.50	24	2.00	8.00	21	1.50	8.00	19	1.25	7.00	18
6	0.36	5.00	12.00	47	3.00	9.00	38	2.00	8.00	35	1.50	7.25	34
8	0.38	6.50	13.00	75	3.50	9.50	60	2.50	8.40	57	1.75	7.50	55

\* not included in AWWA C153

All dimensions are in inches unless noted otherwise.

All weights are approximate in pounds unless noted otherwise.



**TEES : PO X PO, PO X FLANGE, PO X SWIVEL HYDRANT & CROSSES**

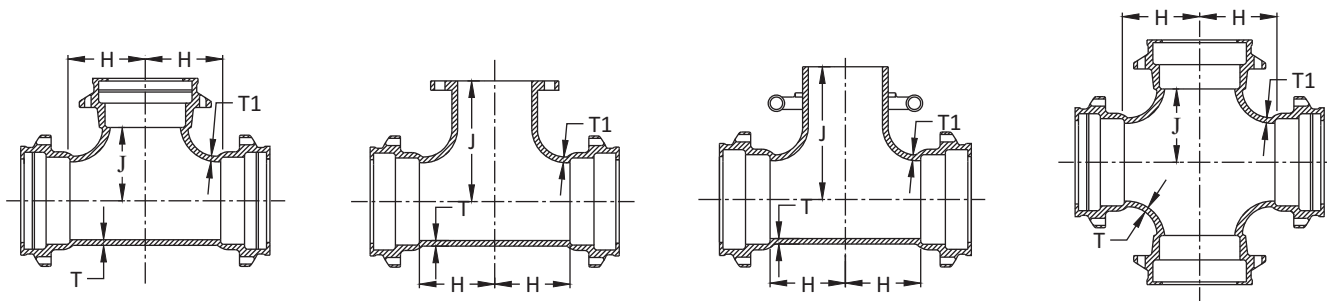

TEES & CROSSES			TEES : PO X PO			TEES : PO X FE*			TEES : PO X ST*			PO CROSSES		
SIZE	T	T1	H	J	WT	H	J	WT	H	J	WT	H	J	WT
4 X 4	0.34	0.34	4.00	4.00	40	4.50	6.50	47	---	---	---	4.00	4.00	55
6 X 4	0.36	0.34	4.00	5.00	50	4.50	8.00	60	---	---	---	---	---	---
6 X 6	0.36	0.36	5.00	5.00	59	5.50	8.00	69	6.00	9.50	71	5.00	5.00	74
8 X 4	0.38	0.34	4.00	6.50	75	4.50	9.00	81	---	---	---	---	---	---
8 X 6	0.38	0.36	5.00	6.50	88	5.50	9.00	87	6.00	10.50	87	5.00	6.50	103
8 X 8	0.38	0.38	6.50	6.50	99	6.50	9.00	115	---	---	---	6.50	6.50	115
10 X 4	0.40	0.34	4.00	7.50	95	4.50	11.00	97	---	---	---	4.00	7.50	116
10 X 6	0.40	0.36	5.00	7.50	103	5.50	11.00	114	7.00	12.50	100	---	---	---
10 X 8	0.40	0.38	6.50	7.50	122	6.50	11.00	133	---	---	---	6.50	7.50	150
10 X 10	0.40	0.40	7.50	7.50	134	7.50	11.00	165	---	---	---	7.50	7.50	160
12 X 4	0.42	0.34	4.00	8.75	122	4.50	12.00	125	---	---	---	---	---	---
12 X 6	0.42	0.36	5.00	8.75	126	5.50	12.00	131	7.00	13.50	138	---	---	---
12 X 8	0.42	0.38	6.50	8.75	148	6.50	12.00	166	---	---	---	6.50	8.75	171
12 X 10	0.42	0.40	7.50	8.75	161	7.50	12.00	142	---	---	---	7.50	8.75	176
12 X 12	0.42	0.42	8.75	8.75	192	8.75	12.00	210	---	---	---	8.75	8.75	216
14 X 6	0.47	0.36	6.50	10.50	176	---	---	---	---	---	---	6.50	10.50	189
14 X 8	0.47	0.38	---	---	---	---	---	---	---	---	---	7.50	10.50	204
14 X 10	0.47	0.40	8.50	10.50	195	---	---	---	---	---	---	8.50	10.50	222
14 X 12	0.47	0.42	9.50	10.50	196	---	---	---	---	---	---	9.50	10.50	239
14 X 14	0.47	0.47	10.50	10.50	209	---	---	---	---	---	---	10.50	10.50	270
16 X 6	0.50	0.36	6.50	11.50	221	6.50	15.00	236	6.50	15.00	229	6.50	11.50	234
16 X 8	0.50	0.38	7.50	11.50	257	7.50	15.00	269	---	---	---	7.50	11.50	245
16 X 10	0.50	0.40	8.50	11.50	232	8.50	15.00	310	---	---	---	8.50	11.50	268
16 X 12	0.50	0.42	9.50	11.50	288	9.50	15.00	348	---	---	---	9.50	11.50	274
16 X 14	0.50	0.47	10.50	11.50	349	10.50	15.00	342	---	---	---	10.50	11.50	322
16 X 16	0.50	0.50	12.50	12.50	460	11.50	15.00	355	---	---	---	12.50	12.50	417
18 X 6	0.54	0.36	6.50	12.50	320	6.50	15.50	301	6.00	17.00	260	---	---	---
18 X 8	0.54	0.38	7.50	12.50	325	7.50	15.50	319	---	---	---	7.50	12.50	363
18 X 10	0.54	0.40	8.50	12.50	344	8.50	15.50	337	---	---	---	---	---	---
18 X 12	0.54	0.42	9.50	12.50	385	---	---	---	---	---	---	---	---	---
18 X 14	0.54	0.47	10.50	12.50	352	10.50	15.50	393	---	---	---	---	---	---
18 X 16	0.54	0.50	11.50	12.50	362	11.50	15.50	420	---	---	---	---	---	---
18 X 18	0.54	0.54	14.00	14.00	550	---	---	---	---	---	---	---	---	---
20 X 6	0.57	0.36	6.50	14.00	355	6.50	17.00	341	7.00	17.50	400	---	---	---
20 X 10	0.57	0.40	9.00	14.00	369	9.00	17.00	420	---	---	---	---	---	---
20 X 12	0.57	0.42	10.00	14.00	457	---	---	---	---	---	---	---	---	---
20 X 14	0.57	0.47	11.00	14.00	484	11.00	17.00	474	---	---	---	---	---	---
20 X 16	0.57	0.50	12.00	14.00	610	12.00	18.00	498	---	---	---	---	---	---
20 X 18	0.57	0.54	13.00	14.00	639	13.00	18.00	528	---	---	---	---	---	---
20 X 20	0.57	0.57	15.00	15.00	644	---	---	---	---	---	---	---	---	---
24 X 6	0.61	0.36	7.00	16.00	450	7.00	19.00	420	7.00	19.50	525	---	---	---
24 X 8	0.61	0.38	8.00	16.00	492	---	---	---	---	---	---	---	---	---
24 X 10	0.61	0.40	9.00	16.00	520	9.00	19.00	468	---	---	---	---	---	---
24 X 12	0.61	0.42	10.00	16.00	541	10.00	19.00	503	---	---	---	---	---	---
24 X 14	0.61	0.47	11.00	16.00	715	11.00	19.00	531	---	---	---	---	---	---
24 X 16	0.61	0.50	12.00	16.00	755	12.00	19.00	555	---	---	---	---	---	---
24 X 18	0.61	0.54	13.00	16.00	708	---	---	---	---	---	---	---	---	---
24 X 20	0.61	0.57	14.00	16.00	845	---	---	---	---	---	---	---	---	---
24 X 24	0.61	0.61	17.00	17.00	884	---	---	---	---	---	---	17.00	17.00	1056

All dimensions are in inches unless noted otherwise.

All weights are approximate in pounds unless noted otherwise.

\* not included in AWWA C153

### TEES : PO X PE\*

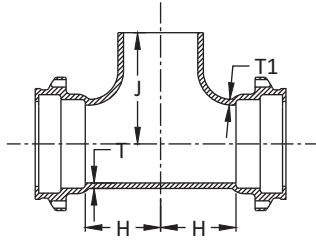

SIZE	T	T1	H	J	WT
6 X 6	0.36	0.36	5.00	11.50	55
8 X 6	0.38	0.36	5.00	12.50	75
12 X 6	0.42	0.36	5.50	15.50	130

### REDUCERS : PO X PO, PO X FE

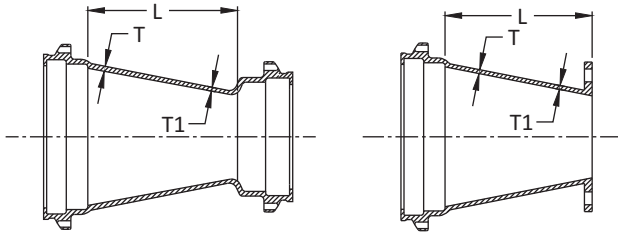

REDUCERS			PO X PO		PO X FE*	
SIZE	T	T1	L	WT	L	WT
6 x 4	0.36	0.34	4.00	30	6.00	32
8 x 4	0.38	0.34	5.00	42	7.00	46
8 x 6	0.38	0.36	4.00	43	6.00	47
10 x 4	0.40	0.34	7.00	53	9.00	55
10 x 6	0.40	0.36	5.00	58	7.00	59
10 x 8	0.40	0.38	4.00	62	6.00	61
12 x 4	0.42	0.34	9.00	70	11.00	78
12 x 6	0.42	0.36	7.00	77	9.00	73
12 x 8	0.42	0.38	5.00	80	7.00	74
12 x 10	0.42	0.40	4.00	82	6.00	95
14 x 6	0.47	0.36	9.00	84	11.00	121
14 x 8	0.47	0.38	7.00	85	9.00	128
14 x 10	0.47	0.40	5.00	87	7.00	127
14 x 12	0.47	0.42	4.00	104	6.00	144
16 x 6	0.50	0.36	11.00	138	13.00	133
16 x 8	0.50	0.38	9.00	137	11.00	141
16 x 10	0.50	0.40	7.00	130	9.00	158
16 x 12	0.50	0.42	5.00	135	7.00	172
16 x 14	0.50	0.47	4.00	139	6.00	196
18 x 8	0.54	0.38	13.00	140	16.00	157
18 x 10	0.54	0.40	10.00	142	14.00	175
18 x 12	0.54	0.42	7.00	167	12.00	215
18 x 14	0.54	0.47	6.00	217	11.50	234
18 x 16	0.54	0.50	5.00	202	10.50	246
20 x 10	0.57	0.40	14.00	180	16.00	234
20 x 12	0.57	0.42	12.00	205	---	---
20 x 14	0.57	0.47	10.00	233	13.50	249
20 x 16	0.57	0.50	7.00	250	11.50	272
20 x 18	0.57	0.54	4.00	248	---	---
24 x 12	0.61	0.42	16.00	308	18.00	262
24 x 14	0.61	0.47	14.00	340	17.50	315
24 x 16	0.61	0.50	12.00	324	15.50	328
24 x 18	0.61	0.54	10.00	390	---	---
24 x 20	0.61	0.57	7.00	421	---	---

### 45° PO LATERALS\*

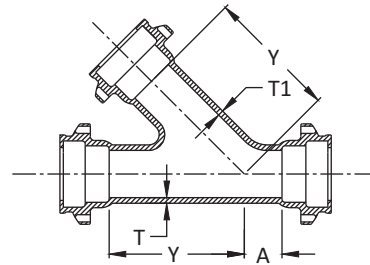

SIZE	T	T1	A	Y	WT
4 X 4	0.34	0.34	2.50	11.00	55
6 X 4	0.36	0.34	3.00	13.00	76
6 X 6	0.36	0.36	3.00	13.00	85
8 X 4	0.38	0.34	3.50	16.00	89
8 X 6	0.38	0.36	3.50	16.00	125
8 X 8	0.38	0.38	3.50	16.00	140
10 X 4	0.40	0.34	3.50	19.00	144
10 X 6	0.40	0.36	3.50	19.00	154
10 X 8	0.40	0.38	3.50	19.00	160
10 X 10	0.40	0.40	3.50	19.00	170
12 X 4	0.42	0.34	4.50	22.50	224
12 X 6	0.42	0.36	4.50	22.50	236
12 X 8	0.42	0.38	4.50	22.50	259
12 X 10	0.42	0.40	4.50	22.50	282
12 X 12	0.42	0.42	4.50	22.50	300
14 X 6	0.47	0.36	0.00	19.50	236
14 X 8	0.47	0.38	1.50	21.00	255
14 X 10	0.47	0.40	3.00	22.50	325
14 X 14	0.47	0.47	6.00	25.00	475
16 X 6	0.50	0.36	0.00	21.00	281
16 X 8	0.50	0.38	1.00	22.50	305
16 X 12	0.50	0.42	3.50	25.00	346
16 X 16	0.50	0.50	6.00	28.00	380
18 X 18	0.75	0.75	7.00	29.00	812

\* not included in AWWA C153

All dimensions are in inches unless noted otherwise.

All weights are approximate in pounds unless noted otherwise.

**ADAPTER : PO X FLANGE\***

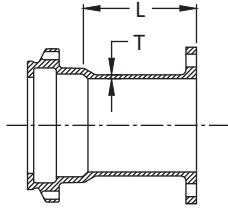

SIZE	L	T	WT
4	3.50	0.34	22
6	3.50	0.36	34
8	3.50	0.38	46
10	3.50	0.40	59
12	3.50	0.42	98
14	5.00	0.47	113
16	5.00	0.50	180
24	5.00	0.61	308

**PO TAPPED TEES & CROSSES**

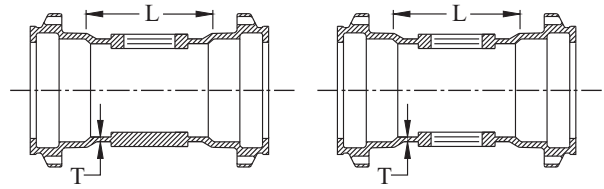

SIZE	T	L	TAP SIZE	WT
4	0.34	6.00	2.0	35
6	0.36	6.00	2.0	45
8	0.38	6.00	2.0	61
10	0.40	6.00	2.0	100
12	0.42	6.00	2.0	140

**REDUCERS : PE X SMALL END PO\***

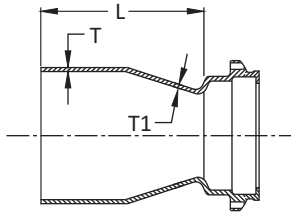

SIZE	T	T1	L	WT
6 x 4	0.37	0.35	9.50	27
8 x 4	0.39	0.35	9.50	29
8 x 6	0.39	0.37	9.50	37
12 x 6	0.43	0.37	12.50	63
12 x 8	0.43	0.39	10.50	64

**PO TRANSITION GASKETS\***

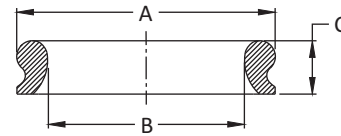

SIZE	A	B	C	WT
4	5.74	4.18	1.00	0.50
6	7.86	6.31	1.10	0.70
8	10.15	8.32	1.29	0.80
10	12.22	10.30	1.36	1.00
12	14.34	12.70	1.45	1.20

**PO SOLID & TAPPED CAPS & PLUGS\***

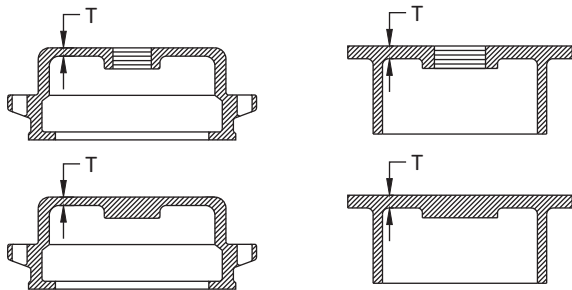

SIZE	T	MAX TAP	CAPS WT	PLUGS WT
4	0.37	2	13	12
6	0.39	2	20	17
8	0.41	2	30	29
10	0.44	2	40	36
12	0.46	2	62	47
14	0.60	2 1/2	70	74
16	0.83	2 1/2	156	144
24	0.90	3	212	202

**PO GASKETS\***

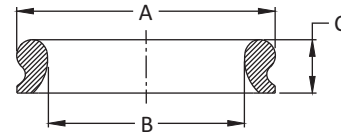

SIZE	A	B	C	WT
4	5.74	4.54	1.00	0.40
6	7.86	6.64	1.00	0.60
8	10.15	8.73	1.21	0.70
10	12.22	10.80	1.30	0.90
12	14.34	12.92	1.30	1.00
14	16.90	15.90	1.65	1.30
16	19.01	17.01	1.65	1.45
18	21.13	19.13	1.65	1.60
20	23.25	21.25	1.65	1.75
24	27.48	25.48	1.65	1.95

All dimensions are in inches unless noted otherwise.

All weights are approximate in pounds unless noted otherwise.

\* not included in AWWA C153





# SIP Industries

Quality Manufacturers Since 1960

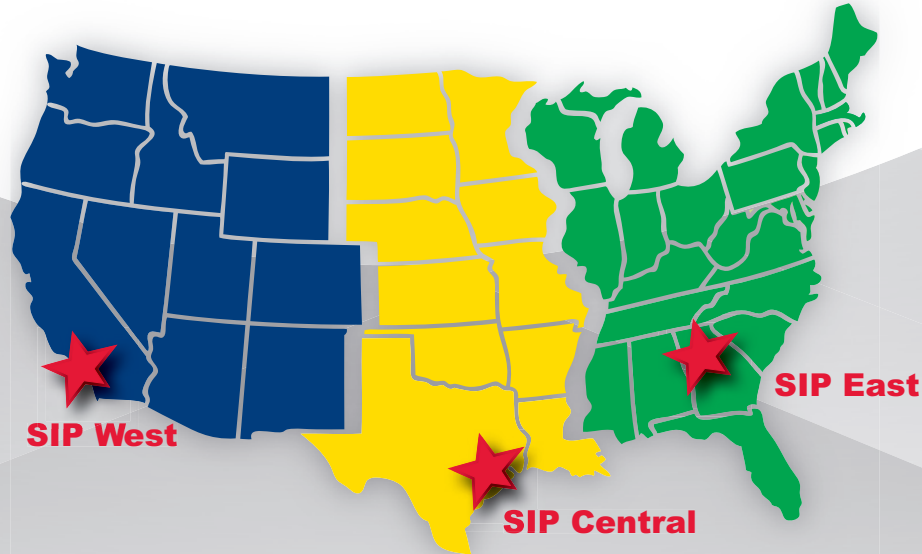

## PRODUCT LINE

### AWWA DI Fittings & Accessories

- C153 Compact MJ Fittings and Acc. 2" - 64"
- C110 Full Body MJ Fittings 2" - 64"
- C153 Trim Tyton® Push-On Fittings 4" - 24"
- C110 Flange Fittings 2" - 64"
- MJ x MJ Adapter for Connecting MJ Bells 3" - 24"
- Stainless Steel & Blue T-Bolts
- Made in India, China & Mexico
- Bare, Cement, Zinc, FBE & Other Linings

### Joint Restraint System

- EZD Joint Restraint for DI Pipe 3" - 48"
- EZDTP Joint Restraint Tandem for DI Pipe 3" - 48"
- EZDPTP Joint Restraint for Push-On Joints DI Pipe 3" - 48"
- Ductile Iron Retainer Glands 3" - 30"
- FAR / FAH Flange Adapter for DI Pipe 3" - 48"
- EZFA Restrained Flange Adapter for DI and PVC Pipe 3" - 36"
- EZPVC Joint Restraint for PVC Pipe 3" - 36"
- ULTRA Joint Restraint for PVC Pipe 4" - 12"
- EZPVCPTP Joint Restraint for Push-On Joints PVC Pipe 14" - 36"
- PTPVC Pipe to Pipe Restraint 4" - 48"
- PTPDF Pipe to MJ Fittings Restraint 4" - 48"
- PTPFC Pipe to PVC Fittings Restraint 4" - 12"
- Made in China & USA
- EZ Shield or Shop Coating

### Municipal Construction Castings

- Manhole Rings and Cover
- Frames and Grates
- Valve Boxes and Service Boxes
- Water Meter Covers and Boxes
- Cleanout and Monument Boxes
- Detectable Warning Plates
- Extension Rings
- Trench Grates and Tree Grates
- Made in India & USA

### Fabrication Products for DI Pipe

- High Hub Flanges Class 150 and 250. 3" - 64"
- Threaded Bell Flanges 3" - 48"
- Anchor Flanges 3" - 60"
- Filler Flanges 4" - 30"

### Other Products and Services

- All Thread Rod
- Pipe Lube and Hydraulic Cement
- Socket Clamps and Lugs
- Flange Packs
- OEM Castings



**SIP CORPORATE** 8876 Gulf Freeway, Suite 500, Houston, TX 77017

**SIP CENTRAL** 2900 Patio Drive, Houston, TX 77017

**SIP EAST** 600 Rayloc Drive, Atlanta, GA 30336

**SIP WEST** 8333 Almeria Avenue, Fontana, CA 92335

Phone: 877-921-6111 or 713-923-6111 | Fax: 713-923-6114 | [www.sipindustries.com](http://www.sipindustries.com) | [sales@sipindustries.com](mailto:sales@sipindustries.com)