



SIP Industries
Quality Manufacturers Since 1960

EZ GRIP®

HIGH PRESSURE TANDEM JOINT RESTRAINT FOR DUCTILE IRON PIPE

The EZ GRIP® Tandem

Joint Restraint is a proven design, offering an efficient, reliable, and inexpensive method of restraining Ductile Iron Pipe with Mechanical Joint Pipe or appurtenances, by integrating a series of gripping wedges into a Mechanical Joint follower gland.

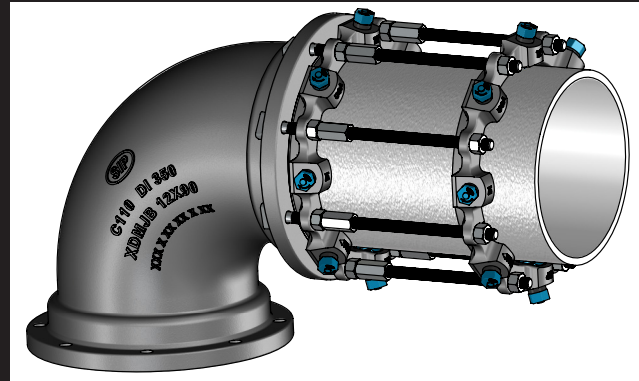

ADVANTAGES, BENEFITS, FEATURES

- The EZ GRIP® Tandem Joint Restraint eliminates clamps, tie rods, cables, and thrust blocks.
- The EZ GRIP® Tandem Joint Restraint performs optimally on any Ductile Iron Pipe conforming to the ANSI/AWWA C151/A21.51 Standard and is compatible with all mechanical joint sockets of the ANSI/AWWA C111/A21.11, C110/A21.10, and C153/121.53 Standards.
- The EZ GRIP® Tandem may also be used on steel pipe sizes 3" to 12" with the use of a transition gasket. For applications on steel sizes 14" and larger, please contact our Engineering Services.
- The EZ GRIP® Tandem Joint Restraint is rated pressure is noted on the technical detail table and has a minimum safety factor of at least 2:1 of the pressure rating of pipes.
- The grip on the pipe increases as the hydrostatic pressure increases.
- The hex head of the actuating screw is the same size as a standard T-bolt nut (1 1/4"), and requires wrenches for the coupling nut and rods.
- The hex head of the torque control screw is designed to shear at a preset limit, assuring proper installation and to prevent damage to the pipe or lining.
- When the actuating screw is rotated in the correct direction (clockwise) the torque control head breaks off, exposing a 5/8" hex head, indicating proper deployment of the wedge.
- After removing the 1-1/4" torque control hex head, a 5/8" hex head remains for multiple disassembly and re-installation, if necessary.
- EZ GRIP® Tandem Joint Restraints offers 5° deflection up to sizes 12", 3° on 14"-24", 2° on 30"-36" & 1° on 42"- 48".
- The gland, wedges, and screws are manufactured from high strength Ductile Iron in compliance with the ASTM A536 Standard, Grade 65-45-12.
- The wedges are heat treated to a minimum hardness of 370 BHN.
- The EZ GRIP® Tandem Joint Restraint is designed to perform optimally for potable and recycled water, and for wastewater applications.
- The EZ GRIP® Tandem Joint Restraint for Ductile Iron Pipe is provided with a coating that is compatible with most field applied coatings
- The standard color for the EZ GRIP® Tandem for DI Pipe is black.
- **IMPORTANT NOTE:** Not for use on Spigot End of M.J. x P.E. Fittings or on P.E. x P.E. Fittings

Available:  Import

Toll Free 877- 921-6111
www.sipindustries.com

Installation Procedure

Installation Procedure for restraining mechanical joint appurtenances on ductile iron pipe conforming to ANSI/AWWA C151/A21.51.

- 1 Clean the socket and the plain end. Lubrication and additional cleaning should be provided by brushing both the gasket and the plain end with soapy water or an approved pipe lubrication meeting the requirement of ANSI/ AWWA C111/ A21.11, just prior to slipping the gasket onto the plain end for joint assembly. Place both glands on the plain end with lip extensions toward the plain end, followed by the gasket. **NOTE:** In cold weather, it is preferable to warm the gasket to facilitate assembly of the joint. Also, the pipe ends need to be clean and free from defects that would impede the wedge actions.
- 2 Insert the pipe into the socket and press the gasket firmly and evenly into the gasket recess. Keep the joint straight during assembly.
- 3 Push the first gland toward the socket and center it around the pipe with the gland lip against the gasket.
- 4 Insert T-bolts and hand tighten nuts. Make deflection after joint assembly but before tightening bolts.
- 5 Tighten the torque control hex heads on the first gland clockwise until all the wedges are in firm contact with the pipe wall. Continue tightening torque control hex heads in an alternating manner until all torque control hex heads have been twisted off.

- 6 Tighten the torque control hex heads on the first gland clockwise until all the wedges are in firm contact with the pipe wall. Continue tightening torque control hex heads in an alternating manner until all torque control hex heads have been twisted off.

- 7 Thread the coupling nuts to the exposed ends of the first glands T-Bolts by making sure they make contact with the first gland T-bolt nuts. Slide the second gland towards fist gland; slide the rods through second gland, thread rods to the coupling nuts and make sure they make contact with the first gland T-bolt inside coupling nut (butted against each other).

- 8 Push the second gland away from the first gland and hand tighten nuts so that about 1/2" of threads are exposed on the rods.

- 9 Pull back the second gland to make contact with the nuts on the rods.

- 10 Tighten the torque control hex heads on the second gland clockwise until all the wedges are in firm contact with the pipe wall. Continue tightening torque control hex heads in an alternating manner until all torque control hex heads have been twisted off.

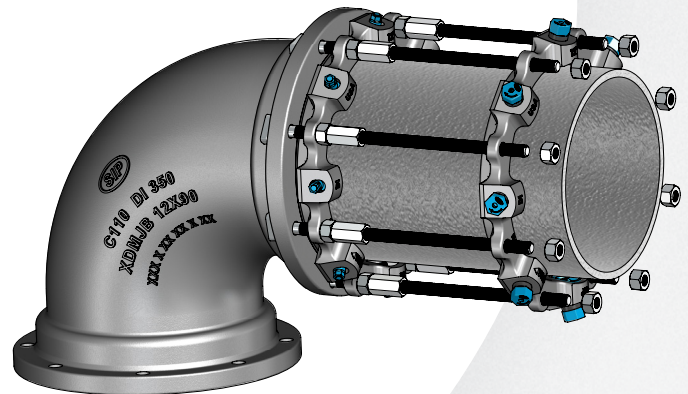
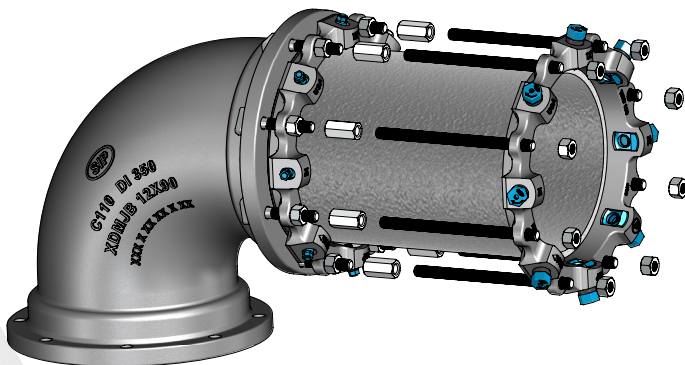

RECOMMENDED TORQUE (T-HEAD BOLTS & NUTS)*

PIPE SIZE (IN)	BOLT SIZE (IN)	RANGE OF TORQUE (FT-LBS)
3	5/8	45 - 60
4 - 24	3/4	75 - 90
30 - 36	1	100 - 120
42 - 48	1 1/4	120 - 150

BREAK-AWAY HEX NUT TORQUE RANGES

SIZE (IN)	RANGE OF TORQUE (FT-LBS)
3 - 24	80 - 90
30 - 48	115 - 135

* Requirement of AWWA C600

If it is necessary to disassemble, a 5/8" hex head is provided on the wedge screws.

For re-installation, first confirm that all wedges are in their sockets, and then follow the installation instructions, using a torque indicating wrench to tighten the 5/8" hex head to 100 ft-lbs for sizes 3"-24", and to 125 ft-lbs for sizes 30"-48".

* If installing on steel pipe 3"-12", a Transition gasket is necessary for proper joint sealing.

Toll Free 877-921-6111

www.sipindustries.com

HIGH PRESSURE TANDEM JOINT RESTRAINT FOR DUCTILE IRON PIPE

Technical Data

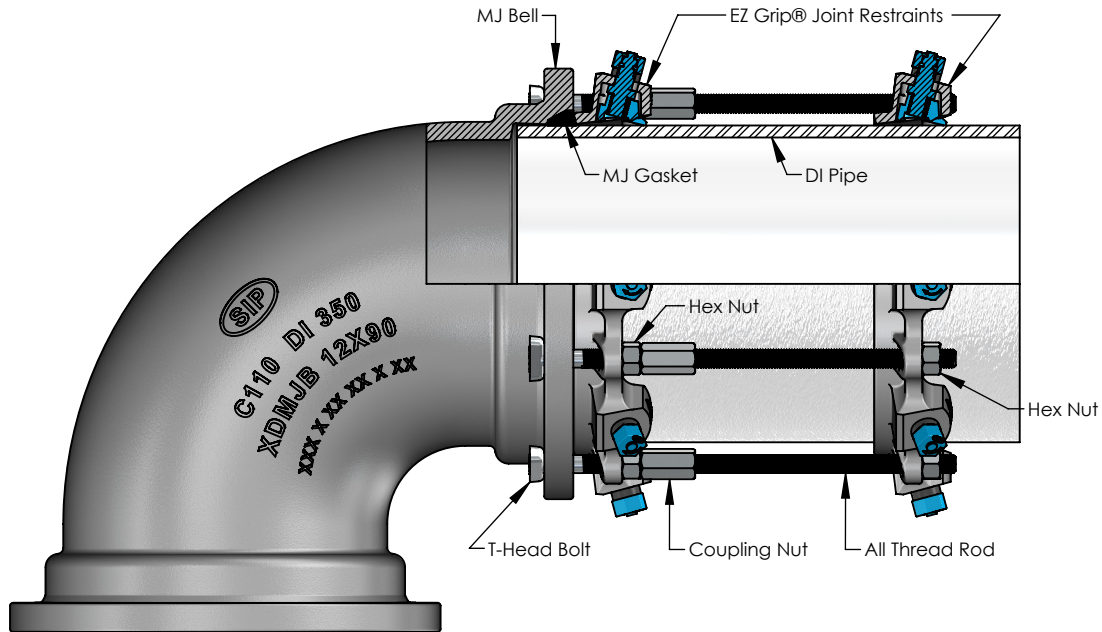

EZ GRIP® TANDEM DI RESTRAINTS SPECIFICATIONS

Size	Series Number	DI Pipe OD	All Thread Rod Size	T-Head Bolt	Coupling Nut	Max Pressure Rating (PSI)*	Approx. Weight (LBS)
3	EZDTP03	3.96	5/8 X 6	5/8 X 4	5/8 X 2 1/8	700	20
4	EZDTP04	4.80	3/4 X 12	3/4 X 4 1/2	3/4 X 2 1/4	700	30
6	EZDTP06	6.90	3/4 X 12	3/4 X 4 1/2	3/4 X 2 1/4	700	40
8	EZDTP08	9.05	3/4 X 12	3/4 X 4 1/2	3/4 X 2 1/4	700	50
10	EZDTP10	11.10	3/4 X 12	3/4 X 4 1/2	3/4 X 2 1/4	600	70
12	EZDTP12	13.20	3/4 X 12	3/4 X 5	3/4 X 2 1/4	600	90
14	EZDTP14	15.30	3/4 X 12	3/4 X 5 1/2	3/4 X 2 1/4	500	140
16	EZDTP16	17.40	3/4 X 12	3/4 X 5 1/2	3/4 X 2 1/4	500	160
18	EZDTP18	19.50	3/4 X 12	3/4 X 5 1/2	3/4 X 2 1/4	350	180
20	EZDTP20	21.60	3/4 X 12	3/4 X 5 1/2	3/4 X 2 1/4	350	190
24	EZDTP24	25.80	3/4 X 12	3/4 X 6	3/4 X 2 1/4	350	295
30	EZDTP30	32.00	1 X 12	1 X 7 1/2	1 X 2 3/4	300	520
36	EZDTP36	38.30	1 X 12	1 X 7 1/2	1 X 2 3/4	300	615
42	EZDTP42	44.50	1 1/4 X 12	1 1/4 X 9 1/2	1 1/4 X 3	300	1120
48	EZDTP48	50.80	1 1/4 X 12	1 1/4 X 9 1/2	1 1/4 X 3	300	1360

All dimensions are in inches, unless otherwise noted

* Pressure ratings based on use with PC350 or TC50 (or above) DI pipe

Please refer to our web page www.sipindustries.com for up to date product data and technical advisories



SIP Industries
Quality Manufacturers Since 1960

EZ GRIP®

HIGH PRESSURE TANDEM JOINT RESTRAINT FOR DUCTILE IRON PIPE

SAMPLE SPECIFICATIONS

The EZ Grip Tandem mechanical joint restraining mechanism and the follower glands shall be designed and manufactured as one integral device providing for a joint seal and performing as a joint restraint for high pressure applications. This shall be achieved by two glands with series of individually activated wedges with connection rods gripping the outside wall of the Ductile Iron Pipe. The grip of the wedges shall increase as the hydrostatic pressure increases.

The hex head of the actuating screw shall be designed to break off at a preset torque. After the removal of the 1-1/4" torque control hex head, a 5/8" hex head on the actuating screw shall remain, to allow for the disassembly and re-installation of the gland and restraint.

The gland, screws, and wedges shall be manufactured of high strength ductile iron in accordance with the ASTM A536 Standard, Grade 65-45-12. The wedges shall be heat treated to a minimum hardness of 370 BHN.

The EZ Grip Tandem mechanical joint restraint mechanism shall be rated for higher working water pressure as noted in technical data sheet and provides 2:1 safety factor on the pressure rating of the pipe used. The restraint device shall perform optimally on any Ductile Iron Pipe conforming to the ANSI/AWWA C151/A21.51 Standard and the gland shall comply with all applicable dimensions of, and be compatible with, all mechanical joint sockets of ANSI/AWWA C111/A21.11, C110/A21.10, and C153/121.53 Standards.

The EZ Grip Tandem mechanical joint restraint mechanism for ductile iron pipe shall be approved by Factory Mutual for sizes 3"-12" and listed by Underwriters Laboratories for sizes 3"-24". The restraint device for Ductile Iron Pipe shall be SIP Industries series EZDT or equal.

Available: Import



PRODUCT LINE

AWWA DI Fittings & Accessories

- C153 Compact MJ Fittings and Acc. 2" - 64"
- C110 Full Body MJ Fittings 2" - 64"
- C153 Trim Tyton® Push-On Fittings 4" - 24"
- C110 Flange Fittings 2" - 64"
- MJ x MJ Adapter for Connecting MJ Bells 3" - 24"
- Stainless Steel & Blue T-Bolts
- Made in India, China & Mexico
- Bare, Cement, Zinc, FBE & Other Linings

Joint Restraint System

- EZD Joint Restraint for DI Pipe 3" - 48"
- EZDTP Joint Restraint Tandem for DI Pipe 3" - 48"
- EZDPTP Joint Restraint for Push-On Joints DI Pipe 3" - 48"
- Ductile Iron Retainer Glands 3" - 30"
- FAR / FAH Flange Adapter for DI Pipe 3" - 48"
- EZFA Restrained Flange Adapter for DI and PVC Pipe 3" - 36"
- EZPVC Joint Restraint for PVC Pipe 3" - 36"
- ULTRA Joint Restraint for PVC Pipe 4" - 12"
- EZPVCPTP Joint Restraint for Push-On Joints PVC Pipe 14" - 36"
- PTPVC Pipe to Pipe Restraint 4" - 48"
- PTPDF Pipe to MJ Fittings Restraint 4" - 48"
- PTPFC Pipe to PVC Fittings Restraint 4" - 12"
- Made in China & USA
- EZ Shield or Shop Coating

Municipal Construction Castings

- Manhole Rings and Cover
- Frames and Grates
- Valve Boxes and Service Boxes
- Water Meter Covers and Boxes
- Cleanout and Monument Boxes
- Detectable Warning Plates
- Extension Rings
- Trench Grates and Tree Grates
- Made in India & USA

Fabrication Products for DI Pipe

- High Hub Flanges Class 150 and 250. 3" - 64"
- Threaded Bell Flanges 3" - 48"
- Anchor Flanges 3" - 60"
- Filler Flanges 4" - 30"

Other Products and Services

- All Thread Rod
- Pipe Lube and Hydraulic Cement
- Socket Clamps and Lugs
- Flange Packs
- OEM Castings



SIP INDUSTRIES
SERAMPORE
SINCE 1960

SIP CORPORATE 8876 Gulf Freeway, Suite 500, Houston, TX 77017

SIP CENTRAL 2900 Patio Drive, Houston, TX 77017

SIP EAST 600 Rayloc Drive, Atlanta, GA 30336

SIP WEST 8333 Almeria Avenue, Fontana, CA 92335

Phone: 877-921-6111 or 713-923-6111 | Fax: 713-923-6114 | www.sipindustries.com | sales@sipindustries.com