



SIP Industries
Quality Manufacturers Since 1960

EZ GRIP®
MJ ADAPTER

MJ x MJ ADAPTER FOR CONNECTING TWO MJ BELLS

The EZ GRIP®

MJ x MJ Adapter is a proven design, offering an efficient, reliable and inexpensive method to connect Mechanical Joint Bells directly to one another in situations where spacing and restraining options are minimal.

ADVANTAGES, BENEFITS, FEATURES

- Eliminates the need for Thrust Blocks and Rods & Clamps restraint methods
- Allows for a secure connection using the minimal space requirements of 1-1/4"
- Main Body & Spacers made from Ductile Iron in accordance with ASTM A536, Grade 65-45-12
- Performs to a Maximum Working Pressure of 350 PSI
- Uses Standard MJ Gaskets, SBR, per ANSI/AWWA C111/A21.11
- T-Head & Pigtail Bolts and all Nuts all made from HSLA Steel per ANSI/AWWA C111/A21.11
- Available in Asphaltic Seal Coat in accordance with ANSI/AWWA C104/A21.4 or Fusion- Bonded Epoxy (FBE) in accordance with ANSI/AWWA C116/A21.16
- Offered in sizes from 3" to 12"

Available:  Import

Toll Free 877-921-6111
www.sipindustries.com



Installation Procedure: 3"-12"

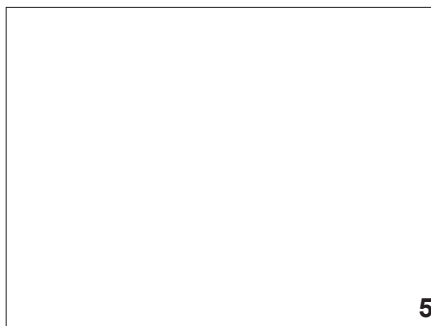
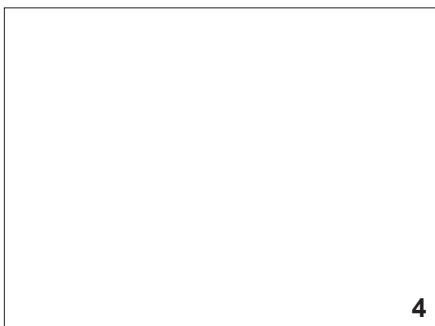
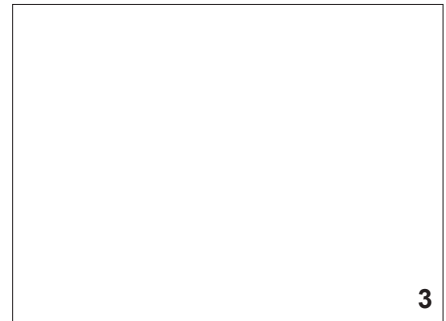
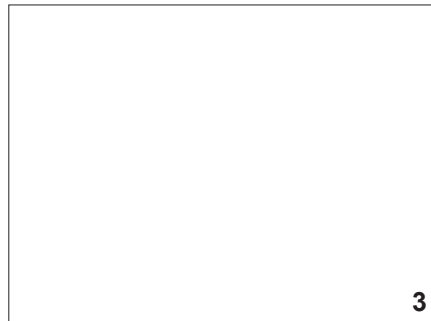
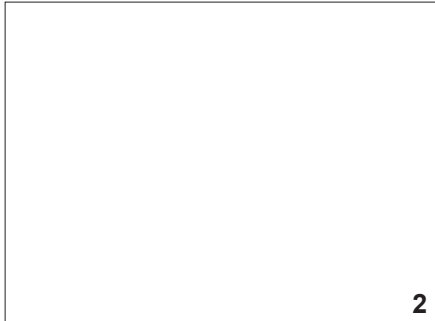

1 Thoroughly clean both MJ Bells of any foreign material; dirt, rust, etc., and wipe clean the spigot ends of the MJ Adapter.

2 Lubricate MJ Gaskets and adaptor spigots with appropriate lubricant or soapy water. Gaskets must be installed with the flat side of the gasket flush against Center Ring of the Adapter.

3 Insert one Spigot end of the MJ Adapter, with gasket, into the first MJ Bell. Then push other MJ Bell onto other gasketed Adapter Spigot. Align the Slots of the Adapter's Center Ring with the bolt holes of the MJ Bells.

4 Insert bolts through the assembly, then slide the Spacers provided, onto the bolts such that the wider flat side of the Spacer faces the nut.

Note: Pigtail Bolts are provided for Slotted bolt connections on Valves or Fittings, or can be used in Solid bolt holes.

5 Assemble the nuts onto the bolts using a standard 1 1/8" wrench/socket. Tighten in an alternate pattern (star pattern) until they are within torque ranges suggested on the side, dependent on Fitting Size.

SIZE (IN)	RECOMMENDED TORQUE (T-HEAD, PIGTAIL EYE BOLTS)
	(FT-LBS)*
3	45 -60
4 - 12	75 - 90

* Requirement of AWWA C600



MJ x MJ ADAPTER FOR CONNECTING TWO MJ BELLS

Technical Data

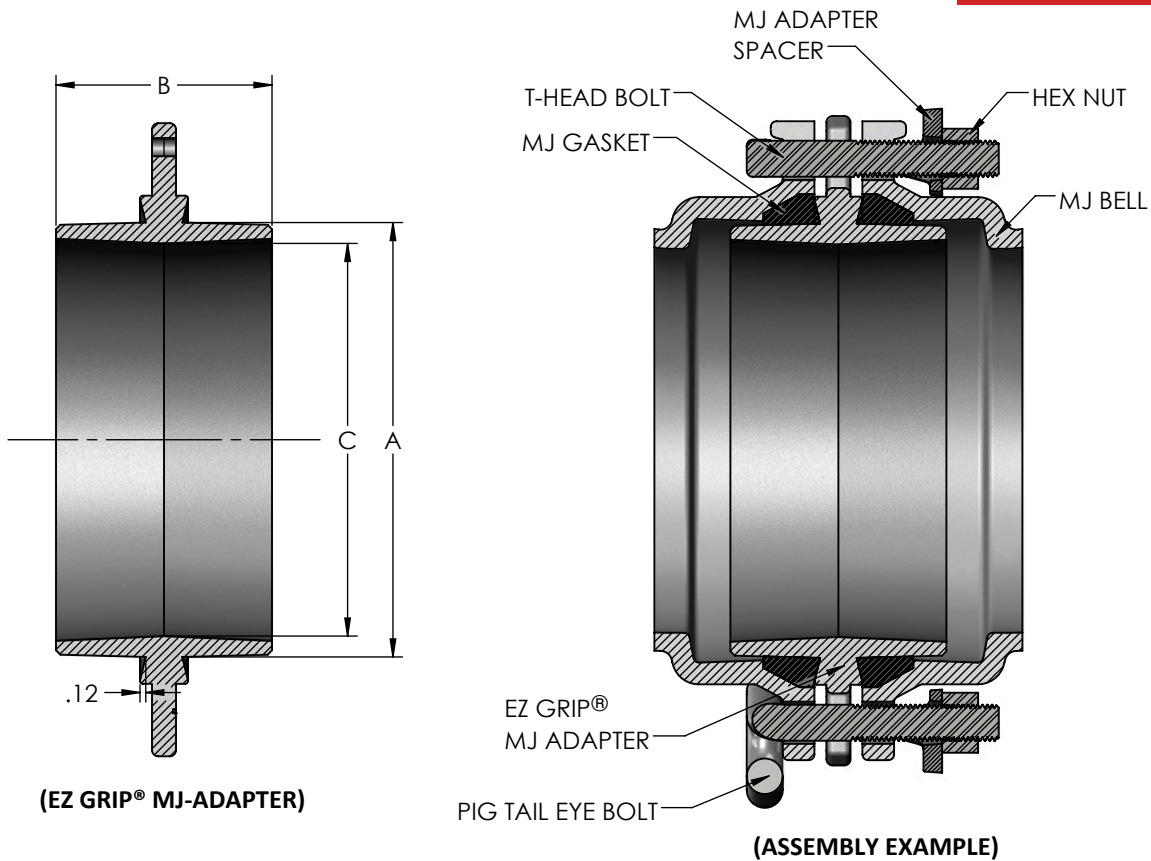

EZ GRIP[®] MJ-ADAPTER SPECIFICATIONS

SIZE	T-HEAD BOLT QTY.	PIG TAIL EYE BOLT QTY.	MJ ADAPTER SPACER QTY.	A	B	C	APPROX. WEIGHT W/ACCESSORIES (LBS.)
3	4	N/A	4	3.96	4.50	3.18	11
4	4	N/A	4	4.80	4.50	4.08	17
6	4	2	6	6.90	4.50	6.13	24
8	4	2	6	9.05	4.50	8.18	30
10	4	4	8	11.10	4.60	10.18	40
12	4	4	8	13.20	4.60	12.31	46

All the dimensions are in inches unless specified otherwise.

BOLTS IN C153 ACCESSORY PACK							
SIZE (IN)	T-HEAD BOLT		PIGTAIL EYE BOLT		STANDARD MJ GASKET QTY	WRENCH/SOCKET SIZE (IN)	RECOMMENDED TORQUE (T-HEAD, PIGTAIL EYE BOLTS) (FT-LBS)*
	(IN)	QTY	(IN)	QTY			
3	5/8 x 4	4	N/A	N/A	2	1 1/16	45 - 60
4	3/4 x 4 1/2	4	N/A	N/A	2	1 1/8	75 - 90
6	3/4 x 4 1/2	4	3/4 x 4 1/2	2	2	1 1/8	75 - 90
8	3/4 x 4 1/2	4	3/4 x 4 1/2	2	2	1 1/8	75 - 90
10	3/4 x 5	4	3/4 x 5	4	2	1 1/8	75 - 90
12	3/4 x 5	4	3/4 x 5	4	2	1 1/8	75 - 90

BOLTS IN C110 ACCESSORY PACK							
SIZE (IN)	T-HEAD BOLT		PIGTAIL EYE BOLT		STANDARD MJ GASKET QTY	WRENCH/SOCKET SIZE (IN)	RECOMMENDED TORQUE (T-HEAD, PIGTAIL EYE BOLTS) (FT-LBS)*
	(IN)	QTY	(IN)	QTY			
3	5/8 x 5	4	N/A	N/A	2	1 1/16	45 - 60
4	3/4 x 5 1/2	4	N/A	N/A	2	1 1/8	75 - 90
6	3/4 x 5 1/2	4	3/4 x 5 1/2	2	2	1 1/8	75 - 90
8	3/4 x 5 1/2	4	3/4 x 5 1/2	2	2	1 1/8	75 - 90
10	3/4 x 5 1/2	4	3/4 x 5 1/2	4	2	1 1/8	75 - 90
12	3/4 x 5 1/2	4	3/4 x 5 1/2	4	2	1 1/8	75 - 90

* Requirement of AWWA C600

Toll Free 877-921-6111

www.sipindustries.com



SIP Industries
Quality Manufacturers Since 1960

EZ GRIP®
MJ ADAPTER

SAMPLE SPECIFICATIONS

MJ x MJ ADAPTER FOR CONNECTING TWO MJ BELLS

A bolt-through restraint mechanism shall be used to connect Mechanical Joint Bells to Mechanical Joint Bells on either Valves or Fittings without the use of pipe.

The MJ x MJ Adapter design will incorporate a Spigot x Spigot bolt-through restraint mechanism that allows for this connection using T-Head or Pigtail Bolts with Nuts and Spacers.

The MJ x MJ Adapter and spacers shall be manufactured from high strength Ductile Iron in accordance with ASTM A536, Grade 65-45-12. T-Head and Pigtail bolts and all Nuts shall be high strength low alloy steel and shall conform to ANSI/AWWA C111/A21.11. Mechanical Joint Gaskets shall be Standard SBR (styrene butadiene rubber) (Other rubber compounds available upon request) and conform to ANSI/AWWA C111/A21.11.

The MJ x MJ Adapter shall have a maximum water working pressure of 350 PSI for sizes 3"-12" and shall be used with standard Mechanical Joint Fittings and Valves. The MJ x MJ Adapter shall be supplied with standard NSF-61 Approved asphaltic seal coat that conforms to ANSI/AWWA C104/A21.4 or a Fusion-Bonded Epoxy (FBE) coating in accordance with ANSI/AWWA C116/A21.16.

The MJ x MJ Adapter Kit shall come complete with one MJ x MJ adapter, two standard SBR Mechanical Joint Gaskets, and all required T-Head bolts or Pigtail bolts and Nuts and Spacers.

The MJ x MJ Adapter shall be SIP Industries EZ Grip MJ x MJ Adapter or an approved equal.

Available: Import

AWWA DI Fittings & Accessories

C153 Compact MJ Fittings and Acc. 2" – 48"
C110 Full Body MJ Fittings 2" - 48"
C153 Push-On Fittings 4" - 24"
C110 Flange Fittings 2" - 60"
Stainless Steel & Blue T-Bolts
Ductile Iron Retainer Glands
Made in India, China & Mexico
Cement, Fusion Bonded Epoxy & P401 lining.

Joint Restraint System

EZD Joint Restraint for DI Pipe 3" - 48"
EZP Joint Restraint for PVC Pipe 3" - 36"
PTP Pipe to Pipe Restraint 4" - 36"
PTPDF Pipe to MJ Fittings Restraint 4" - 36"
PTPFC Pipe to PVC Fittings Restraint 4" - 12"
Made in China & USA
Fusion Bonded Epoxy or Shop Coating.

Municipal Construction Castings

Manhole Rings and Cover
Frames and Grates
Valve Boxes and Service Boxes
Water Meter Covers and Boxes
Trench Grates and Tree Grates
Made in India & USA

Fabrication Products for DI Pipe

High Hub Flanges Class 150 and 250. 3" - 64"
Threaded Bell Flanges 3" - 48"
Anchor Flanges 3" - 60"
Filler Flanges 4" - 30"

Other Products and Services

All Thread Rod
Pipe Lube and Hydraulic Cement
Socket Clamps and Lugs
Flange Packs
OEM Castings

SIP West

8333 Almeria Avenue
Fontana, CA 92335

SIP Central

2900 Patio Drive
Houston, TX 77017

SIP East

600 Rayloc Drive
Atlanta, GA 30336